

<b>METROPOLITAN UTILITIES DISTRICT</b>	<b>Construction Standard</b>	No:	<b>8.3.1</b>
Prepared by: Rich Baird	<b>Magnesium Anode Placement &amp; Test Lead Detail (Gas &amp; Water)</b>	Page:	1 of 10
Approved by: James Bartels		<u>Supersedes:</u>	7-29-25
		Effective:	4-23-26
<b>The latest revisions can be found at the end of this document</b>			

**SCOPE:** According to 49 CFR Part [192.455](#), each buried or submerged metallic gas pipeline installed after July 31, 1971 must have a cathodic protection (CP) system designed to protect the pipeline installed and placed in operation within 1 year after completion of construction.

According to 49 CFR Part [192.457](#), except for cast iron (CI) or ductile iron (DI), buried or submerged metallic gas pipelines installed before August 1, 1971, must be cathodically protected in areas in which active corrosion is found.

The District uses sacrificial magnesium anodes to provide cathodic protection for steel gas and water pipelines and appurtenances, small sections of isolated steel gas and water pipe, isolated steel gas components, CI water mains and newly installed DI gas and water mains replacing a section of CI main.

***Note:** Only individuals qualified or directly supervised by qualified individuals are allowed to perform these procedures on gas piping.*

## MAGNESIUM ANODES

Magnesium anodes shall be attached to underground bare steel pipe, coated steel pipe, and electrically isolated steel components to provide cathodic protection. Cathodic protection (CP) is provided by a small DC current flowing from the anode to surrounding soils and then onto the pipe. This voltage can be evaluated with a voltmeter and copper-copper sulfate half-cell. Corrosion Section employees or contractors check the voltage annually on gas pipe for a reading more negative than -850 mV. A reading of -850 mV or more negative is generally considered cathodically protected. If the reading is around or less negative than -850 mV on gas pipe, Corrosion Section employees or contractors will proceed with CP deficiency steps per [1.465.0](#). An example of less negative would be -700 mV.

Exposed CI water pipe and newly installed DI gas and water mains replacing a section of CI main will have anodes attached to slow corrosion and will not be monitored. Monitoring is not necessary since all CI will be abandoned through the CI gas main replacement program.

## WHEN TO INSTALL ANODES

Anodes shall be installed according to [Table 1](#) and [Table 2](#) below.

**TABLE 1 – INSTALLING ANODES ON SERVICES**

<b>Installing Anodes on Gas Services</b>	<b>Size and Installation of Anodes</b>
New steel service (on existing steel main)	17# anode (attach to main) if OD ≤12”
	32# anode (attach to main) if OD > 12”
Exposed existing steel service (steel main <u>not</u> exposed)	17# anode (attach to service)
Exposed existing steel service (steel main exposed)	17# anode (attach to main) if OD ≤12”
	32# anode (attach to main) if O.D. > 12”
Exposed steel service (isolated off of plastic or CI main)	3# anode (attach to service), <b>unless</b> service is >100’, or ≥ 2” or 100% under paving, then attach 17# anode.

<b>METROPOLITAN UTILITIES DISTRICT</b>	<b>Construction Standard</b>	No: <b>8.3.1</b>
	<b>Magnesium Anode Placement &amp; Test Lead Detail (Gas &amp; Water)</b>	Page: 2 of 10
<a href="#">Supersedes:</a> 7-29-25		
Effective: 4-23-26		
Prepared by: Rich Baird		
Approved by: James Bartels		

The latest revisions can be found at the end of this document

**TABLE 2 – INSTALLING ANODES ON MAINS**

Main Description	Gas/Water	Size and Installation of Anodes
New coated steel main	Gas & Water	17# anode 2" thru 6" every 900'
		17# anode 8" thru 12" every 600'
		17# anode 16" thru 24" every 300', or anodes shall be installed according to proposed dwgs. (per Corrosion Engineer)
Exposed coated steel main	Gas & Water	17# anode if OD ≤ 12"
		32# anode if OD > 12"
Exposed bare steel main	Gas & Water	32# anode per 10' of exposed pipe
Buried bare steel main (frequency determined by the Corrosion Engineer)	Gas & Water	32# anode every 10'
Exposed CI main (during repairs, service installation, main replacement, etc.)	Water	32# anode on all sizes or anodes shall be installed according to proposed dwgs.
Exposed DI main (during repairs)	Water	32# anode on all sizes or anodes shall be installed according to proposed dwgs.
Insulated coupling (connecting plastic to CI)	Gas	3# anode on coupling
Insulated coupling (connecting steel to CI)	Gas	17# anode per 400' of isolated steel or anodes shall be installed according to proposed dwgs. (per Corrosion Engineer)
	Water	17# anode per 400' of isolated steel 32# anode on each CI side, all sizes, or anodes shall be installed according to proposed dwgs.
Conductive coupling (connecting DI to CI)	Gas	32# anode on the DI pipe or anodes shall be installed according to proposed dwgs. (per Corrosion Engineer)
	Water	32# anode on the DI pipe 32# anode on each CI side, all sizes, or anodes shall be installed according to proposed dwgs.

<b>METROPOLITAN UTILITIES DISTRICT</b>	<b>Construction Standard</b>	No:	<b>8.3.1</b>
	<b>Magnesium Anode Placement &amp; Test Lead Detail (Gas &amp; Water)</b>	Page:	3 of 10
Prepared by: Rich Baird		<u>Supersedes:</u>	7-29-25
Approved by: James Bartels		Effective:	4-23-26
<b>The latest revisions can be found at the end of this document</b>			

## ANODE AND TEST LEAD ATTACHMENT METHODS

Refer to C.S. [8.3.2](#) (Gas) or C.S. [8.3.3](#) (Water) for the various attachment methods used by the District. Other methods require review by the District’s Engineering Department for approval.

***Note: (Gas & Water)** Test leads shall always be installed when replacing a section of CI with coated steel. Test leads for all other situations may already be in place and will only be installed when directed by Corrosion Section employees.*

***(Gas Only)** Test leads shall always be installed when replacing a section of CI with plastic, and when isolating a steel service.*

## ANODE PLACEMENT RELATIVE TO THE PIPE (Fig 1 & Fig 2)

All anodes should be placed at least 3’ (three feet) from the main. See [Fig 1](#). Never place the anode against the main or against another main that is crossing or is parallel because the anode could cause a main or main section to be shorted to another main or main section. If the main is shorted, it is not receiving enough cathodic protection and will eventually corrode if not corrected.

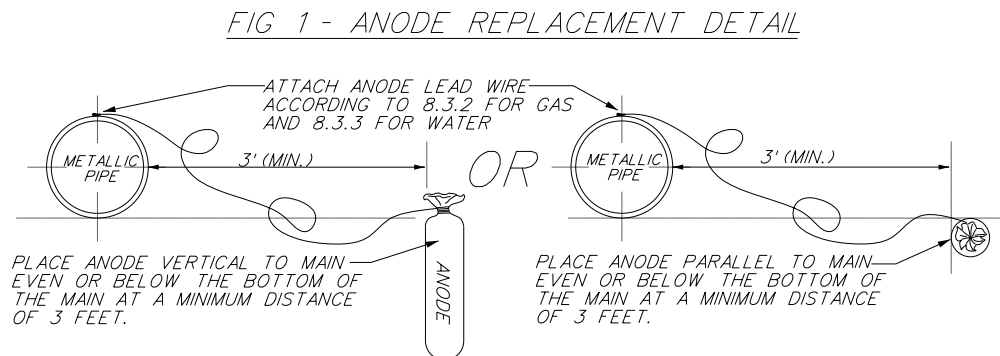

Bare steel mains require more anodes because of the lack of a coating. During surveys, the Corrosion Section employee or contractor may determine that more anodes are required on a certain section of bare steel main because of the low readings. This is often accomplished using a drill rig. Refer to [Fig 2](#) for placement of anodes on bare steel mains using the drill rig.

<b>METROPOLITAN UTILITIES DISTRICT</b>	<b>Construction Standard</b>	No:	<b>8.3.1</b>
	<b>Magnesium Anode Placement &amp; Test Lead Detail (Gas &amp; Water)</b>	Page:	4 of 10
Prepared by: Rich Baird		<u>Supersedes:</u>	7-29-25
Approved by: James Bartels		Effective:	4-23-26

The latest revisions can be found at the end of this document

FIG 2 - ANODE REPLACEMENT DETAIL WHEN USING DRILL RIG

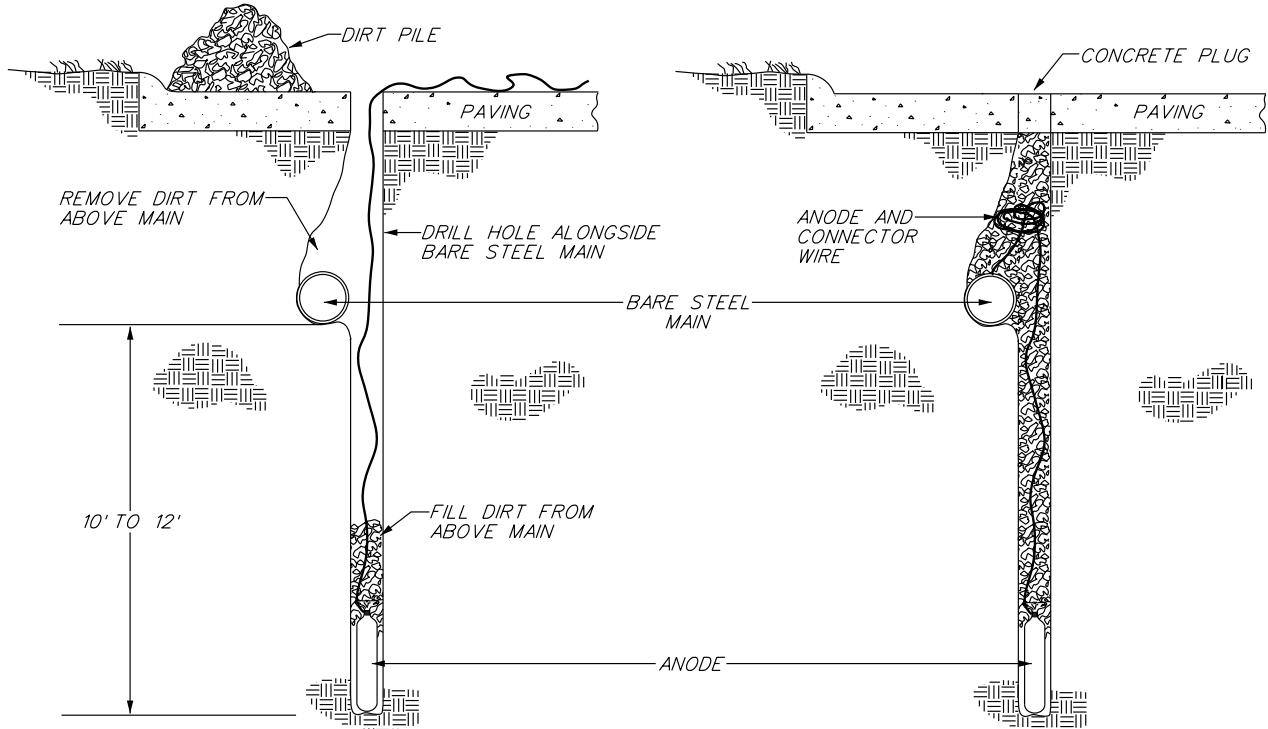

### CATHODIC PROTECTION (CP) TEST LEAD INSTALLATION (FIG 3, 4, & 5)

Anode locations and cathodic protection (CP) test points on all new coated steel mains shall be designated on the proposed drawings by the Corrosion Engineer. The CP test leads may be brought up in a valve or CP test box, above ground pipeline marker, above ground pipeline test station, or at a meter location that is electrically connected to the coated steel main to be monitored. [Fig 3](#) illustrates test leads in a valve or CP test box installed at the ground surface. [Figs 4 & 5](#) show the use of an above ground pipeline marker and an above ground pipeline test station respectively.

FIG 3 - TEST LEAD(S) IN TEST/VALVE BOX DETAIL

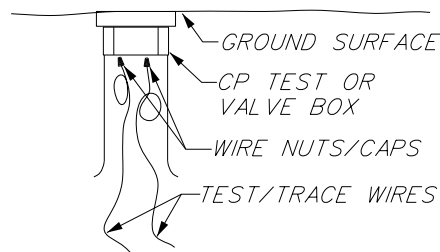

<b>METROPOLITAN UTILITIES DISTRICT</b>	<b>Construction Standard</b>	No: <b>8.3.1</b>
	<b>Magnesium Anode Placement &amp; Test Lead Detail (Gas &amp; Water)</b>	Page: 5 of 10
Prepared by: Rich Baird		<u>Supersedes:</u> 7-29-25
Approved by: James Bartels		Effective: 4-23-26

The latest revisions can be found at the end of this document

FIG 4 - MARKER POST DETAIL WHEN ONLY ONE WIRE IS USED

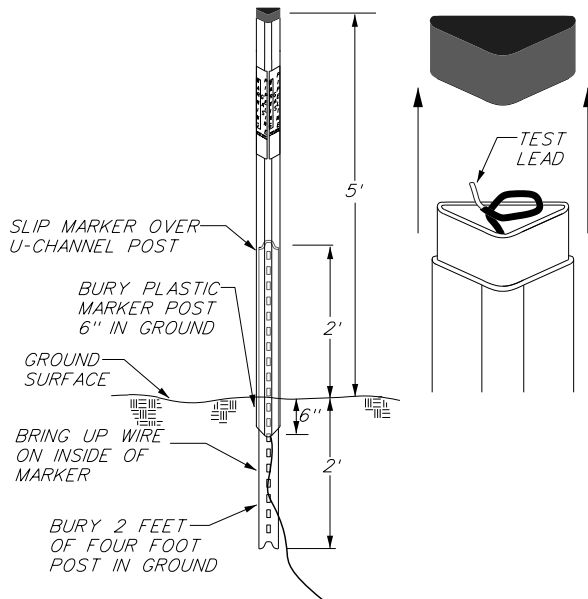
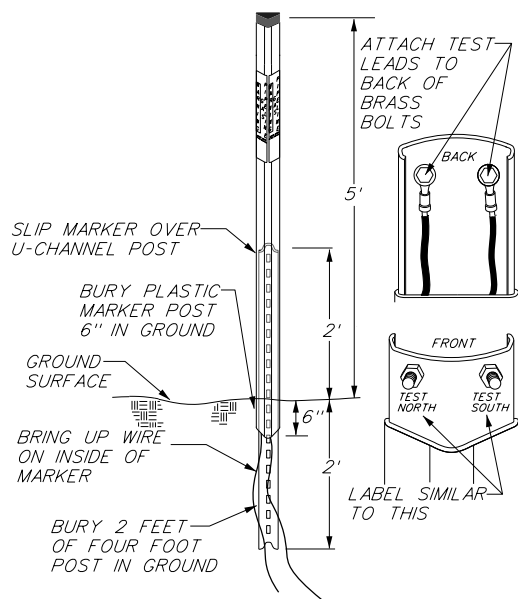

FIG 5 - MARKER POST DETAIL WHEN TWO OR MORE WIRES ARE USED



**ANODE AND TEST LEADS DETAIL ON STEEL PIPE (FIG 6)**

Refer to [Fig 6](#) for the anode and test lead detail on steel pipe.

**Note:** Never connect the test lead directly to the anode lead. If the test lead is directly connected to the anode lead, the CP reading will reflect the condition of the anode rather than the corrosion protection on the main. When the test lead is connected to the main apart from the anode lead and the reading is good, the Corrosion Section employees know the main is being protected because the reading is through the piping.

See the [Records](#) section of this standard for documentation requirements.

FIG 6 - TEST LEAD DETAIL WHEN CALLED OUT ON PROPOSED DRAWING

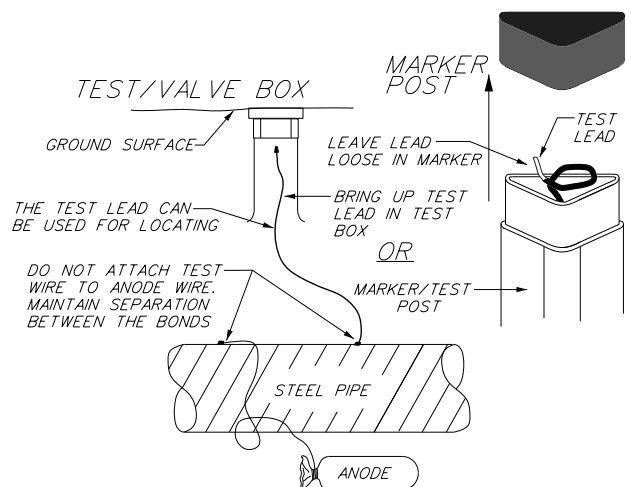

<b>METROPOLITAN UTILITIES DISTRICT</b>	<b>Construction Standard</b>	No: <b>8.3.1</b>
	<b>Magnesium Anode Placement &amp; Test Lead Detail (Gas &amp; Water)</b>	Page: 6 of 10
Prepared by: Rich Baird		<u>Supersedes:</u> 7-29-25
Approved by: James Bartels		Effective: 4-23-26

The latest revisions can be found at the end of this document

### ANODE AND TEST LEADS DETAIL FOR WELD-END INSULATOR (FIG 7)

Insulators on mains are installed to break up a large section of steel pipe into smaller sections of steel pipe that are electrically isolated from each other. This is done at the request of the Corrosion Engineer to make it much easier to track down and locate shorts, low CP readings or any other problems with the cathodic protection system.

Install an anode to each side of the insulator. See [Fig 7](#). Install a CP test lead from each side of the insulator and bring up in a test box or marker. Do not connect the test lead directly to the anode lead. See the anode and test lead boxed-in [Note](#) above.

It is important that the leads from one side of the insulator are not laying across or touching the piping on the other side of the insulator because, over time, the coating on the wire leads could wear through and short one cathodic protection section to the other.

See the [Records](#) section of this standard for documentation requirements.

FIG 7 - INSULATOR CP TEST DETAIL

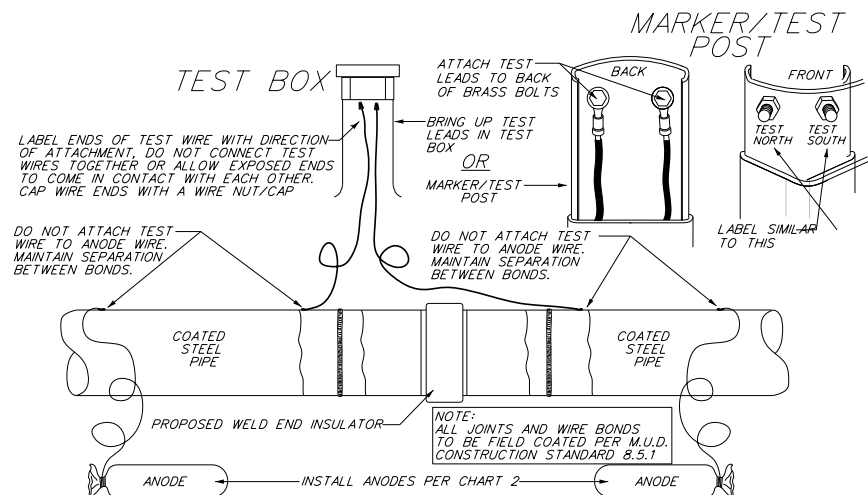

### ANODE AND TEST LEAD FOR PLASTIC CONNECTED TO COATED STEEL MAIN (FIG 8)

When connecting a plastic main to a coated steel main, a 17# anode should be added to the end of the coated steel main. A CP test lead shall be brought up in a test box or marker. Do not connect the test lead directly to the anode lead. See the anode and test lead boxed-in [Note](#) above. The test lead may be connected to the coupling/transition fitting or bonded to the coated steel pipe. See [Fig 8](#).

The trace wire may be brought up in the box or marker post as shown in [Fig 8](#). The bare ends should be capped or taped to keep them from coming in contact with each other and causing a short.

See the [Records](#) section of this standard for documentation requirements.

<b>METROPOLITAN UTILITIES DISTRICT</b>	<b>Construction Standard</b>	No: <b>8.3.1</b>
	<b>Magnesium Anode Placement &amp; Test Lead Detail (Gas &amp; Water)</b>	Page: 7 of 10
Prepared by: Rich Baird		<u>Supersedes:</u> 7-29-25
Approved by: James Bartels		Effective: 4-23-26

The latest revisions can be found at the end of this document

FIG 8 - COATED STEEL TO PLASTIC DETAIL

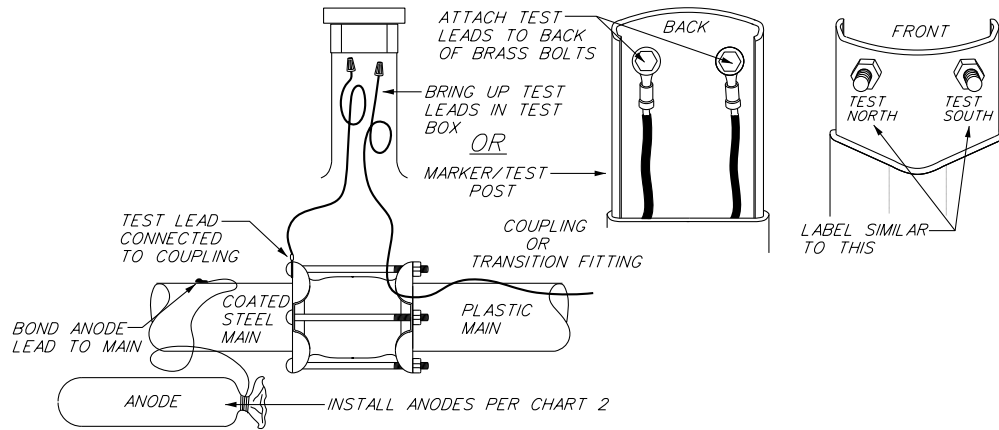

### ANODE AND TEST LEAD FOR PLASTIC REPLACING CAST IRON (FIG 9)

When replacing a section of CI with plastic, both steel couplings are isolated and require a test point in order to monitor CP levels. A 3# anode shall be attached to each coupling. A test lead shall also be attached to each coupling and brought up into a test box or marker post and labeled. In order to check the CP level through the coupling, it is important that the test lead not be directly connected to the anode lead. The test lead may be connected to the crimp clip on the coupling and the anode lead will be connected to one of the couplings bolts through the use of a ring terminal or vice-versa. The test leads will also be used for locating the plastic section.

See the [Records](#) section of this standard for documentation requirements.

FIG 9 - PLASTIC TO CAST IRON CONNECTION DETAIL

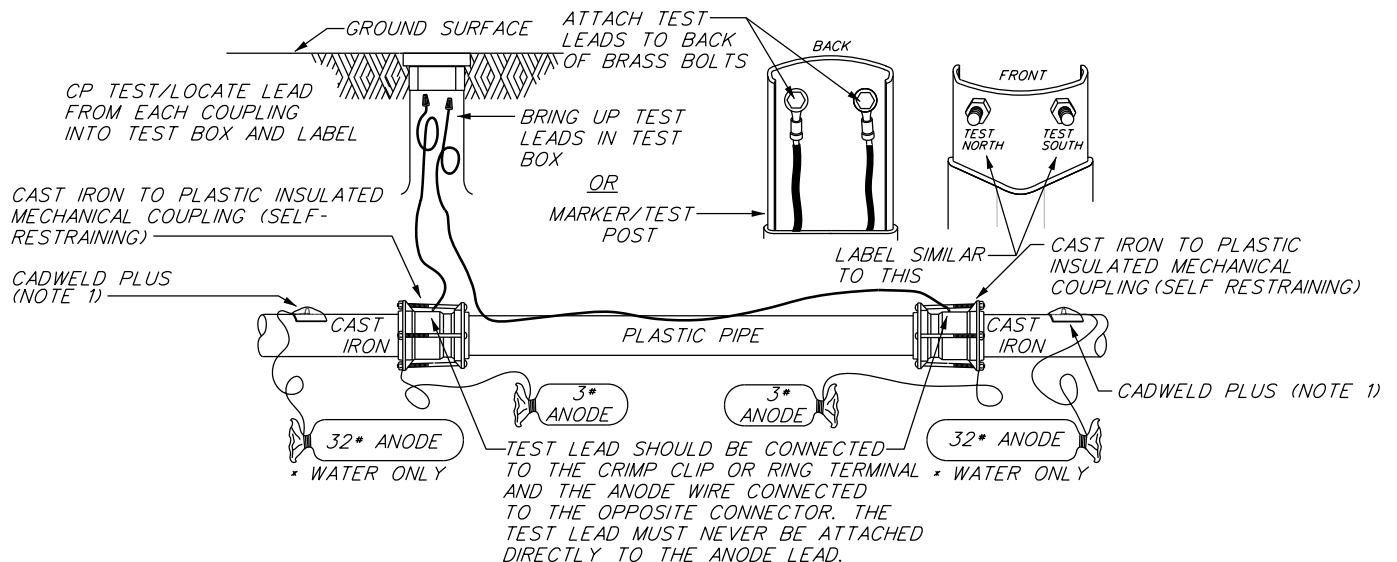

NOTE 1: INSTALL CADWELD PLUS AND COVER WELD AREA WITH PATCH-PAD EXOTHERMIC WELD PROTECTOR, BITUMASTIC COATING OR PRIMER AND COLD WRAP. CADWELD PLUS SHALL BE USED UNLESS FIELD CONDITIONS DO NOT ALLOW. CATHODIC CLAMP TO THEN BE USED WHEN NEEDED AND REQUIRES ENTIRE CIRCUMFERENCE OF PIPE TO BE EXPOSED.

<b>METROPOLITAN UTILITIES DISTRICT</b>	<b>Construction Standard</b>	No:	<b>8.3.1</b>
	<b>Magnesium Anode Placement &amp; Test Lead Detail (Gas &amp; Water)</b>	Page:	8 of 10
Prepared by: Rich Baird		<u>Supersedes:</u>	7-29-25
Approved by: James Bartels		Effective:	4-23-26

The latest revisions can be found at the end of this document

### ANODE AND TEST LEAD FOR COATED STEEL REPLACING CAST IRON (FIG 10)

When a section of CI is replaced with coated steel due to a leak, relocation project, sewer off-set, or other project, a section of isolated steel is created which will require cathodic protection and a test point to monitor CP according to 49 CFR [Part 192](#).

Install 17# anodes according to [Table 2](#). A separate test lead may be attached to the pipe or connected to one of the couplings and brought up into a test box or marker post. See [Fig 10](#). In order to check the CP level through the pipe, it is important that the test lead not be directly connected to the anode lead. See [Note](#) above. Install 32# anodes on each end of the CI main (water only).

See the [Records](#) section of this standard for documentation requirements.

FIG 10 - COATED STEEL TO CAST IRON CONNECTION DETAIL

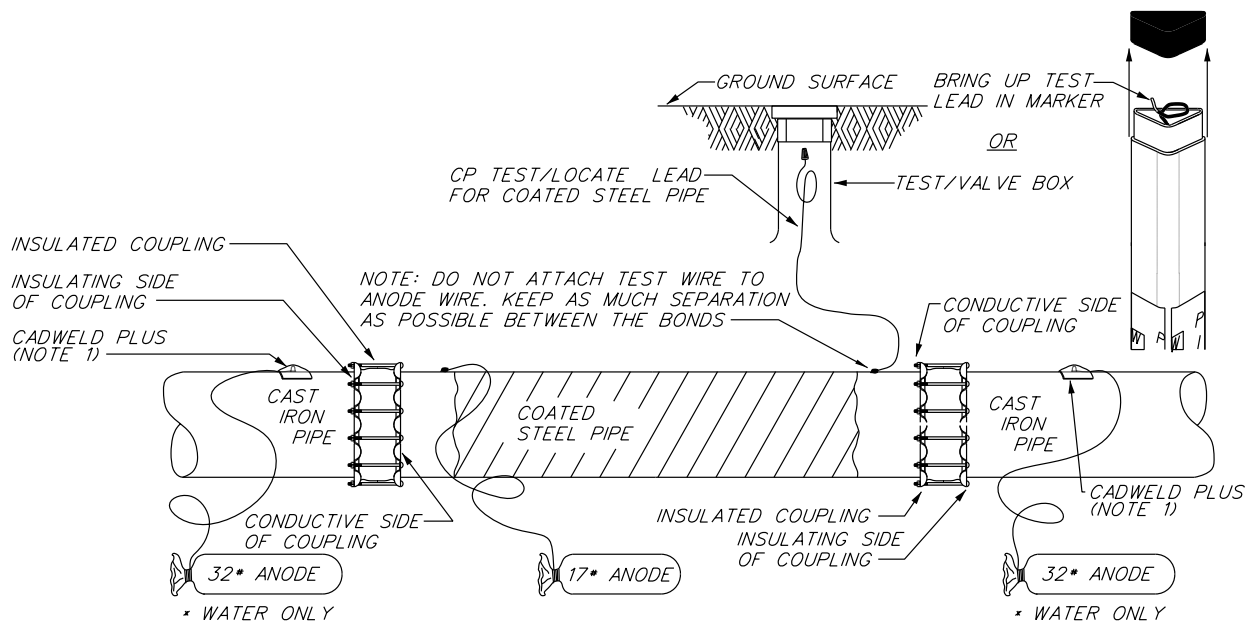

NOTE 1: INSTALL CADWELD PLUS AND COVER WELD AREA WITH PATCH-PAD EXOTHERMIC WELD PROTECTOR, BITUMASTIC COATING OR PRIMER AND COLD WRAP. CADWELD PLUS SHALL BE USED UNLESS FIELD CONDITIONS DO NOT ALLOW. CATHODI-CLAMP TO THEN BE USED WHEN NEEDED AND REQUIRES ENTIRE CIRCUMFERENCE OF PIPE TO BE EXPOSED.

### REPLACING A SECTION OF CAST IRON WITH DUCTILE IRON (FIGS 11 & 12)

When replacing a section of CI with DI, install 32# anodes on each end of the CI main (water only). Install a 32# anode on the DI main. CP on the CI and DI will not be monitored and does not require a test lead. Monitoring is not necessary since all CI will be abandoned through the CI gas main replacement program. Contact Engineering for approval if more than one length of DI is needed to replace one section of CI.

See the [Records](#) section of this standard for documentation requirements.

<b>METROPOLITAN UTILITIES DISTRICT</b>	<b>Construction Standard</b>	No:	<b>8.3.1</b>
	<b>Magnesium Anode Placement &amp; Test Lead Detail (Gas &amp; Water)</b>	Page:	9 of 10
Prepared by: Rich Baird		<u>Supersedes:</u>	7-29-25
Approved by: James Bartels		Effective:	4-23-26

The latest revisions can be found at the end of this document

FIG 11 - REPLACING SECTION OF CAST IRON WITH DUCTILE IRON USING STEEL COUPLINGS

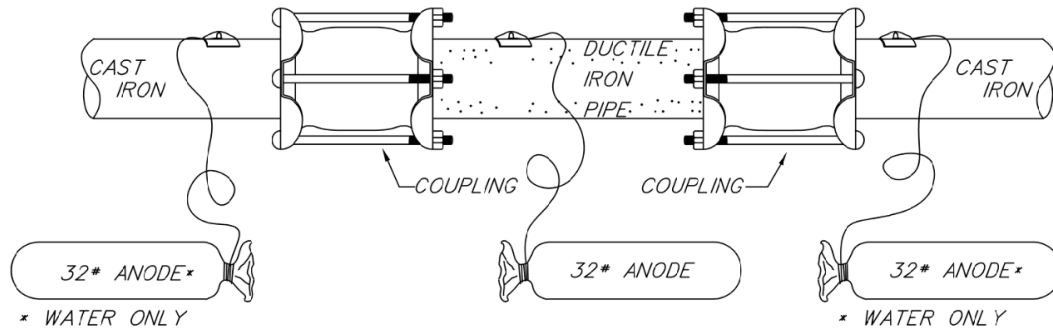

NOTE 1: DO NOT USE MORE THAN ONE LENGTH OF DUCTILE IRON PIPE WITHOUT APPROVAL FROM ENGINEERING

NOTE 2: INSTALL CADWELD PLUS AND COVER WELD AREA WITH PATCH-PAD EXOTHERMIC WELD PROTECTOR, BITUMASTIC COATING OR PRIMER AND COLD WRAP. CADWELD PLUS SHALL BE USED UNLESS FIELD CONDITIONS DO NOT ALLOW. CATHODI-CLAMP TO THEN BE USED WHEN NEEDED AND REQUIRES ENTIRE CIRCUMFERENCE OF PIPE TO BE EXPOSED.

FIG 12 - REPLACING SECTION OF CAST IRON WITH DUCTILE IRON USING STAINLESS STEEL BAND CLAMPS

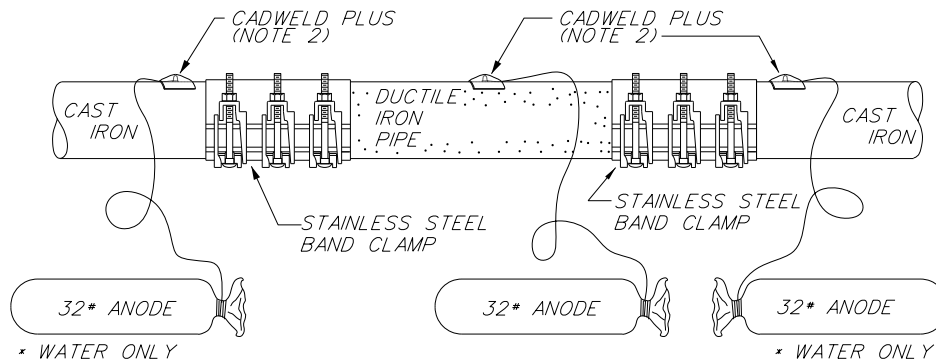

NOTE 1: STAINLESS STEEL BAND CLAMPS RANGE IN SIZE FROM 4" THRU 16". COUPLINGS SHOWN IN FIG 11 MAY BE USED FOR LARGER PIPE.

NOTE 2: INSTALL CADWELD PLUS AND COVER WELD AREA WITH PATCH-PAD EXOTHERMIC WELD PROTECTOR, BITUMASTIC COATING OR PRIMER AND COLD WRAP. CADWELD PLUS SHALL BE USED UNLESS FIELD CONDITIONS DO NOT ALLOW. CATHODI-CLAMP TO THEN BE USED WHEN NEEDED AND REQUIRES ENTIRE CIRCUMFERENCE OF PIPE TO BE EXPOSED.

### TEST POINT AND ANODE PLACEMENT FOR ISOLATED STEEL (SERVICES)

Whenever a main is relocated or replaced with another material, replacing any steel services which would become isolated due to the main project is always considered. Sometimes it is impractical to replace the steel service at that time. When this happens, an anode must be installed on the service according to [Table 1](#) and a test point established.

The anode can be placed at any point on the service that is convenient to the installer. The test point may be established at the meter riser or in a valve box if one is available.

See the [Records](#) section of this standard for documentation requirements.

<b>METROPOLITAN UTILITIES DISTRICT</b>	<b>Construction Standard</b>	No: <b>8.3.1</b>
Prepared by: Rich Baird	<b>Magnesium Anode Placement &amp; Test Lead Detail (Gas &amp; Water)</b>	Page: 10 of 10
Approved by: James Bartels		<a href="#">Supersedes:</a> 7-29-25
		Effective: 4-23-26
<b>The latest revisions can be found at the end of this document</b>		

## RECORDS

The following documentation shall be gathered by the person that installed the anode and test point or by the person that directly supervised the installer. Refer to C.S. [12.1.0](#) for the proper form routing procedures.

To document any test point location, fill out the green [Form 1283-R1](#) and send to the Corrosion Engineer.

In addition to the corrosion forms, document as much information as possible about the test points, anode location, and size on l  
eak reports, service cards, or as-built drawings.

## Revision

The latest revision is detailed on the following page(s).

Pages affected: #1, #2, #3, #4, #5, #10,  
#11 & #12

<b>METROPOLITAN UTILITIES DISTRICT</b>	<b>Construction Standard</b>	No: <b>8.3.1</b>
	<b>Magnesium Anode Placement &amp; Test Lead Detail (Gas &amp; Water)</b>	Page: 1 of 10 <u>Supersedes: 1-29-24-29-25</u> Effective: <u>7-29-25</u>
Prepared by: Rich Baird		
Approved by: James Bartels		

The latest revisions can be found at the end of this document

**SCOPE:** According to 49 CFR-49 Part 192.455, each buried or submerged metallic gas pipeline installed after July 31, 1971 must have a cathodic protection (CP) system designed to protect the pipeline installed and placed in operation within 1 year after completion of construction.

According to 49 CFR-49 Part 192.457, except for cast iron (CI) or ductile iron (DI), buried or submerged metallic gas pipelines installed before August 1, 1971, must be cathodically protected in areas in which active corrosion is found.

The District uses sacrificial magnesium anodes to provide cathodic protection for steel gas and water pipelines and appurtenances, small sections of isolated steel gas and water pipe, isolated steel gas components, ~~cast iron CI~~ water mains and newly installed ~~ductile iron DI~~ gas and water mains replacing a section of CI main.

*Note: Only individuals qualified or directly supervised by qualified individuals are allowed to perform these procedures on gas piping.*

**MAGNESIUM ANODES**

Magnesium anodes shall be attached to underground bare steel pipe, coated steel pipe, and electrically isolated steel components to provide cathodic protection. Cathodic protection (~~CP~~) is provided by a small DC current flowing from the anode to surrounding soils and then onto the pipe. This voltage can be evaluated with a voltmeter and copper-copper sulfate half-cell. Corrosion Section ~~personnel~~ employees or contractors check the voltage annually on gas pipe for a reading more negative than -850 mV. A reading of -850 mV or more negative is generally considered cathodically protected. If the reading is around or less negative than -850 mV on gas pipe, Corrosion Section ~~personnel~~ employees or contractors will proceed with CP deficiency steps per 1.465.0. An example of less negative would be -700 mV.

Exposed ~~cast iron CI~~ water pipe and newly installed ~~ductile iron DI~~ gas and water mains replacing a section of ~~cast iron CI~~ main will have anodes attached to slow corrosion and will not be monitored ~~because CP on cast iron gas is not required by CFR 49 Part 192~~. Monitoring is not necessary since all CI will be abandoned through the CI gas main replacement program.

**WHEN TO INSTALL ANODES**

Anodes shall be installed according to Chart 1 Table 1 and Chart 2 Table 2 below.

**CHART TABLE 1 – INSTALLING ANODES ON SERVICES**

<u>Installing Anodes on Gas Services</u>	<u>Size and Installation of Anodes</u>
<u>New steel service (on existing steel main)</u>	<u>17# anode (attach to main) if OD ≤ 12”</u>
	<u>32# anode (attach to main) if OD &gt; 12”</u>
<u>Exposed existing steel service (steel main not exposed)</u>	<u>17# anode (attach to service)</u>
<u>Exposed existing steel service (steel main exposed)</u>	<u>17# anode (attach to main) if OD ≤ 12”</u>
	<u>32# anode (attach to main) if O.D. &gt; 12”</u>
<u>Exposed steel service (isolated off of plastic or CI)</u>	<u>3# anode (attach to service), unless service is</u>

<b>METROPOLITAN UTILITIES DISTRICT</b>	<b>Construction Standard</b>	No: <b>8.3.1</b>
	<b>Magnesium Anode Placement &amp; Test Lead Detail (Gas &amp; Water)</b>	Page: 2 of 10
Prepared by: Rich Baird		<u>Supersedes: 1-29-24 7-29-25</u>
Approved by: James Bartels	Effective: <u>7-29-25</u>	

The latest revisions can be found at the end of this document

<u>main)</u>	<u>&gt;100', or ≥ 2" or 100% under paving, then attach 17# anode.</u>
--------------	---

<del>INSTALLING ANODES ON GAS SERVICES</del>	<del>SIZE AND INSTALLATION OF ANODES</del>
<del>1) New steel service (on existing steel main)</del>	<del>1) 17# anode (attach to main) if OD ≤ 12" — 32# anode (attach to main) if OD &gt; 12"</del>
<del>2) Exposed existing steel service (steel main not exposed)</del>	<del>2) 17# anode (attach to service)</del>
<del>3) Exposed existing steel service (steel main exposed)</del>	<del>3) 17# anode (attach to main) if OD ≤ 12" — 32# anode (attach to main) if O.D. &gt; 12"</del>
<del>4) Exposed steel service (isolated off of plastic or cast iron main)</del>	<del>4) 3# anode (attach to service), <b>unless</b> service is &gt;100', or ≥ 2" or 100% under paving, then attach 17# anode.</del>

<b>METROPOLITAN UTILITIES DISTRICT</b>	<b>Construction Standard</b>	No: <b>8.3.1</b>
	<b>Magnesium Anode Placement &amp; Test Lead Detail (Gas &amp; Water)</b>	Page: 3 of 10
Prepared by: Rich Baird		<u>Supersedes: 1-29-247-29-25</u>
Approved by: James Bartels		Effective: <u>7-29-25</u>

The latest revisions can be found at the end of this document

**CHART TABLE 2 – INSTALLING ANODES ON MAINS**

<u>Main Description</u>	<u>Gas/Water</u>	<u>Size and Installation of Anodes</u>
<u>New coated steel main</u>	<u>Gas &amp; Water</u>	<u>17# anode 2" thru 6" every 900'</u>
		<u>17# anode 8" thru 12" every 600'</u>
		<u>17# anode 16" thru 24" every 300', or anodes shall be installed according to proposed dwgs. (per Corrosion Engineer)</u>
<u>Exposed coated steel main</u>	<u>Gas &amp; Water</u>	<u>17# anode if OD ≤ 12"</u>
		<u>32# anode if OD &gt; 12"</u>
<u>Exposed bare steel main</u>	<u>Gas &amp; Water</u>	<u>32# anode per 10' of exposed pipe</u>
<u>Buried bare steel main (frequency determined by the Corrosion Engineer)</u>	<u>Gas &amp; Water</u>	<u>32# anode every 10'</u>
<u>Exposed CI main (during repairs, service installation, main replacement, etc.)</u>	<u>Water</u>	<u>32# anode on all sizes or anodes shall be installed according to proposed dwgs.</u>
<u>Exposed DI main (during repairs)</u>	<u>Water</u>	<u>32# anode on all sizes or anodes shall be installed according to proposed dwgs.</u>
<u>Insulated coupling (connecting plastic to CI)</u>	<u>Gas</u>	<u>3# anode on coupling</u>
<u>Insulated coupling (connecting steel to CI)</u>	<u>Gas</u>	<u>17# anode per 400' of isolated steel or anodes shall be installed according to proposed dwgs. (per Corrosion Engineer)</u>
	<u>Water</u>	<u>17# anode per 400' of isolated steel 32# anode on each CI side, all sizes, or anodes shall be installed according to proposed dwgs.</u>
<u>Conductive coupling (connecting DI to CI)</u>	<u>Gas</u>	<u>32# anode on the DI pipe or anodes shall be installed according to proposed dwgs. (per Corrosion Engineer)</u>
	<u>Water</u>	<u>32# anode on the DI pipe 32# anode on each CI side, all sizes, or anodes shall be installed according to proposed dwgs.</u>

<b>INSTALLING ANODES ON MAINS</b>	<b>SIZE AND INSTALLATION OF ANODES</b>
-----------------------------------	--

<b>METROPOLITAN UTILITIES DISTRICT</b>	<b>Construction Standard</b>	No: <b>8.3.1</b>
	<b>Magnesium Anode Placement &amp; Test Lead Detail (Gas &amp; Water)</b>	Page: 4 of 10
Prepared by: Rich Baird		<u>Supersedes: 1-29-24-29-25</u>
Approved by: James Bartels		Effective: <u>7-29-25</u>

The latest revisions can be found at the end of this document

<p><del>1) New coated steel main (gas &amp; water)</del></p> <p><del>2) Exposed coated steel main (gas &amp; water)</del></p> <p><del>3) Exposed bare steel main (gas &amp; water)</del></p> <p><del>4) Buried bare steel main (frequency determined by the Corrosion Engineer) (gas &amp; water)</del></p> <p><del>5) Exposed cast iron main (during repairs, service installation, main replacement, etc.) (water)</del></p> <p><del>6) Exposed ductile iron main (during repairs) (water)</del></p> <p><del>7) Insulated coupling (connecting plastic to cast iron) (gas only)</del></p> <p><del>8) Insulated coupling (connecting steel to cast iron) (gas &amp; water)</del></p> <p><del>9) Conductive coupling (connecting ductile iron to cast iron) (gas &amp; water)</del></p>	<p><del>1) 17# anode 2" thru 6" every 900', 17# anode 8" thru 12" every 600', 17# anode 16" thru 24" every 300', or anodes shall be installed according to proposed dwgs. (per Corrosion Engineer)</del></p> <p><del>2) 17# anode if OD ≤ 12" 32# anode if OD &gt; 12"</del></p> <p><del>3) 32# anode per 10' of exposed pipe</del></p> <p><del>4) 32# anode every 10'</del></p> <p><del>5) (water) 32# anode on all sizes or anodes shall be installed according to proposed dwgs.</del></p> <p><del>6) (water) 32# anode on all sizes or anodes shall be installed according to proposed dwgs.</del></p> <p><del>7) 3# anode on coupling</del></p> <p><del>8) (gas) 17# anode per 400' of isolated steel or anodes shall be installed according to proposed dwgs. (per Corrosion Engineer) (water) 32# anode per 400' of isolated steel 32# anode on each cast iron side, all sizes, or anodes shall be installed according to proposed dwgs.</del></p> <p><del>9) (gas) 32# anode on the ductile iron pipe or anodes shall be installed according to proposed dwgs. (per Corrosion Engineer) (water) 32# anode on the ductile iron pipe 32# anode on each cast iron side, all sizes, or anodes shall be installed according to proposed dwgs.</del></p>
---	--

<b>METROPOLITAN UTILITIES DISTRICT</b>	<b>Construction Standard</b>	No: <b>8.3.1</b>
	<b>Magnesium Anode Placement &amp; Test Lead Detail (Gas &amp; Water)</b>	Page: 5 of 10
Prepared by: Rich Baird		<u>Supersedes: 1-29-247-29-25</u>
Approved by: James Bartels		Effective: <u>7-29-25</u>

The latest revisions can be found at the end of this document

### ANODE AND TEST LEAD ATTACHMENT METHODS

Refer to C.S. [8.3.2](#) (Gas) or C.S. [8.3.3](#) (Water) for the various attachment methods used by the District. Other methods require review by the District’s Engineering Department for approval.

**Note: (Gas & Water)** Test leads shall always be installed when replacing a section of ~~east iron~~ CI with coated steel. Test leads for all other situations may already be in place and will only be installed when directed by Corrosion Section employees.

**(Gas Only)** Test leads shall always be installed when replacing a section of ~~east iron~~ CI with plastic, and when isolating a steel service.

### ANODE PLACEMENT RELATIVE TO THE PIPE (Fig 1 & 2)

All anodes should be placed at least 3’ (three feet) from the main. See [Fig 1](#). Never place the anode against the main or against another main that is crossing or is parallel because the anode could cause a main or main section to be shorted to another main or main section. If the main is shorted, it is not receiving enough cathodic protection and will eventually corrode if not corrected.

FIG 1 - ANODE REPLACEMENT DETAIL

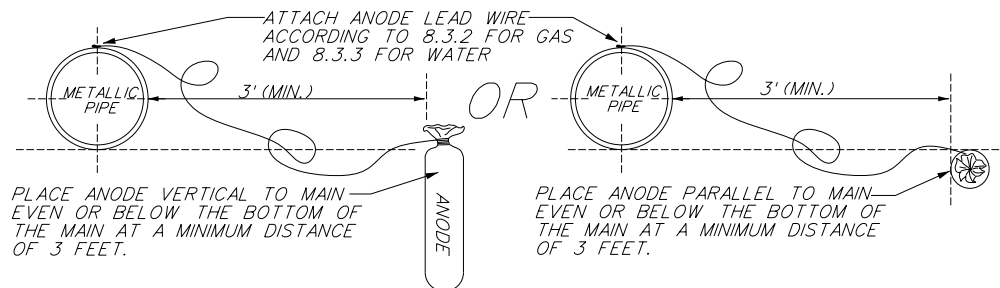

Bare steel mains require more anodes because of the lack of a coating. During surveys, the Corrosion Section ~~personnel~~ employee or contractor may determine that more anodes are required on a certain section of bare steel main because of the low readings. This is often accomplished using a drill rig. Refer to [Fig 2](#) for placement of anodes on bare steel mains using the drill rig.

<b>METROPOLITAN UTILITIES DISTRICT</b>	<b>Construction Standard</b>	No: <b>8.3.1</b>
	<b>Magnesium Anode Placement &amp; Test Lead Detail (Gas &amp; Water)</b>	Page: 10 of 10
Prepared by: Rich Baird		<u>Supersedes: 1-29-247-29-25</u>
Approved by: James Bartels		Effective: <u>7-29-25</u>

The latest revisions can be found at the end of this document

**ANODE AND TEST LEAD FOR COATED STEEL REPLACING CAST IRON (FIG 10)**

When a section of ~~east-ironCI~~ is replaced with coated steel due to a leak, relocation project, sewer off-set, or other project, a section of isolated steel is created which will require cathodic protection and a test point to monitor CP according to 49 CFR 49 Part 192.

Install 17# anodes according to Chart 2 Table 2. A separate test lead may be attached to the pipe or connected to one of the couplings and brought up into a test box or marker post. See Fig 10. In order to check the CP level through the pipe, it is important that the test lead not be directly connected to the anode lead. See Note at the top of page 5 above. Install 32# anodes on each end of the ~~east-ironCI~~ main (water only).

See the Records section of this standard for documentation requirements.

FIG 10 - COATED STEEL TO CAST IRON CONNECTION DETAIL

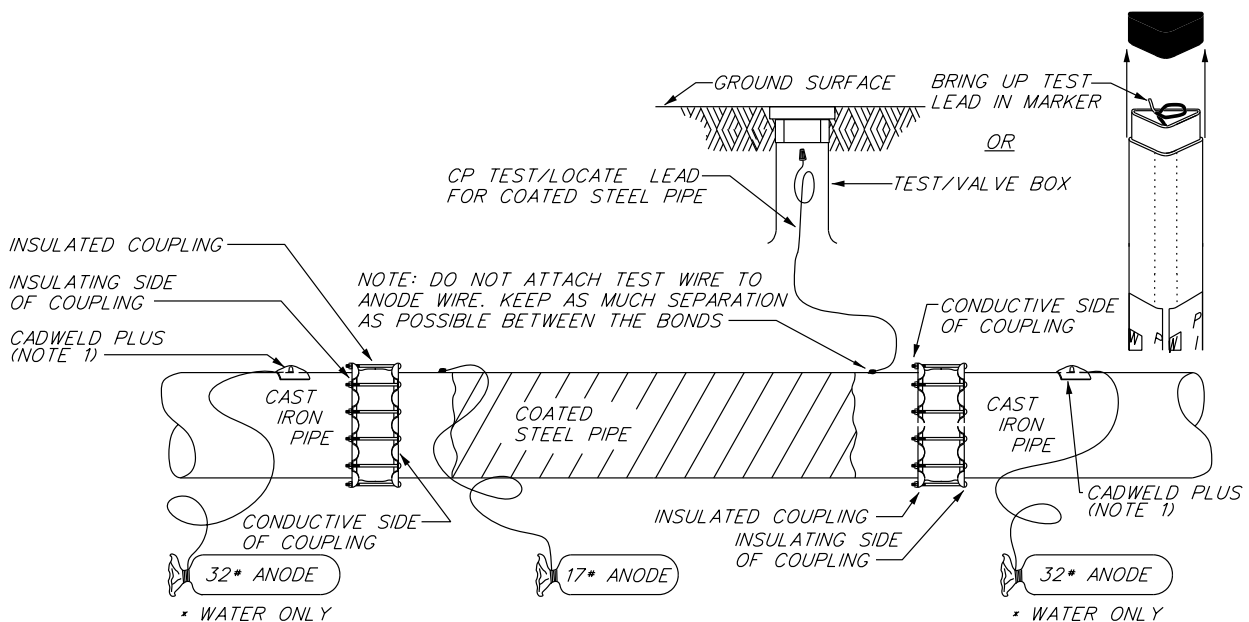

NOTE 1: INSTALL CADWELD PLUS AND COVER WELD AREA WITH PATCH-PAD EXOTHERMIC WELD PROTECTOR, BITUMASTIC COATING OR PRIMER AND COLD WRAP. CADWELD PLUS SHALL BE USED UNLESS FIELD CONDITIONS DO NOT ALLOW. CATHODI-CLAMP TO THEN BE USED WHEN NEEDED AND REQUIRES ENTIRE CIRCUMFERENCE OF PIPE TO BE EXPOSED.

**REPLACING A SECTION OF CAST IRON WITH DUCTILE IRON (FIGS 11 & 12)**

When replacing a section of ~~east-ironCI~~ with ~~ductile-ironDI~~, install 32# anodes on each end of the ~~east-ironCI~~ main (water only). Install a 32# anode on the ~~ductile-ironDI~~ main. CP on the ~~east-ironCI~~ and ~~ductile-ironDI~~ will not be monitored and does not require a test lead. Monitoring is not necessary since all CI will be abandoned through the CI gas main replacement program. Contact Engineering for approval if more than one length of ~~ductile-ironDI~~ is needed to replace one section of ~~east-ironCI~~.

See the Records section of this standard for documentation requirements.

<b>METROPOLITAN UTILITIES DISTRICT</b>	<b>Construction Standard</b>	No: <b>8.3.1</b>
	<b>Magnesium Anode Placement &amp; Test Lead Detail (Gas &amp; Water)</b>	Page: 11 of 10
Prepared by: Rich Baird		<u>Supersedes: 1-29-247-29-25</u>
Approved by: James Bartels		Effective: <u>7-29-25</u>

The latest revisions can be found at the end of this document

FIG 11 - REPLACING SECTION OF CAST IRON WITH DUCTILE IRON USING STEEL COUPLINGS

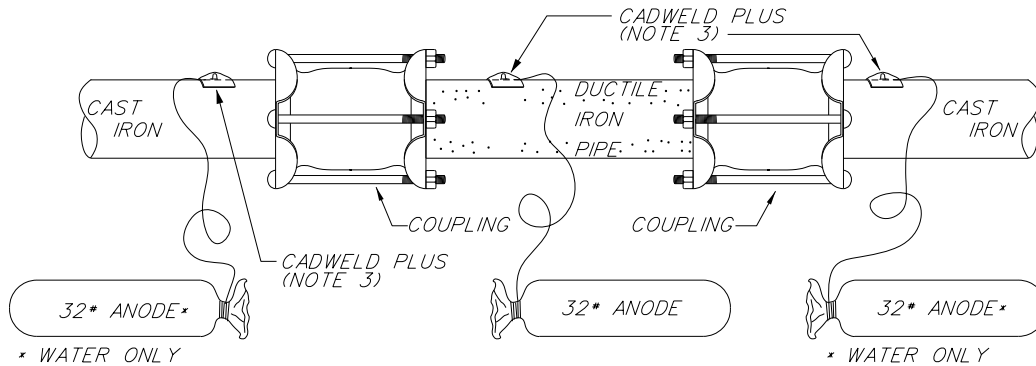

NOTE 1: DO NOT USE MORE THAN ONE LENGTH OF DUCTILE IRON PIPE WITHOUT APPROVAL FROM ENGINEERING

~~NOTE 2: TEST POINT NOT NEEDED BECAUSE MONITORING IS NOT REQUIRED~~

NOTE ~~2~~ <sup>2</sup>: INSTALL CADWELD PLUS AND COVER WELD AREA WITH PATCH-PAD EXOTHERMIC WELD PROTECTOR, BITUMASTIC COATING OR PRIMER AND COLD WRAP. CADWELD PLUS SHALL BE USED UNLESS FIELD CONDITIONS DO NOT ALLOW. CATHODI-CLAMP TO THEN BE USED WHEN NEEDED AND REQUIRES ENTIRE CIRCUMFERENCE OF PIPE TO BE EXPOSED.

FIG 12 - REPLACING SECTION OF CAST IRON WITH DUCTILE IRON USING STAINLESS STEEL BAND CLAMPS

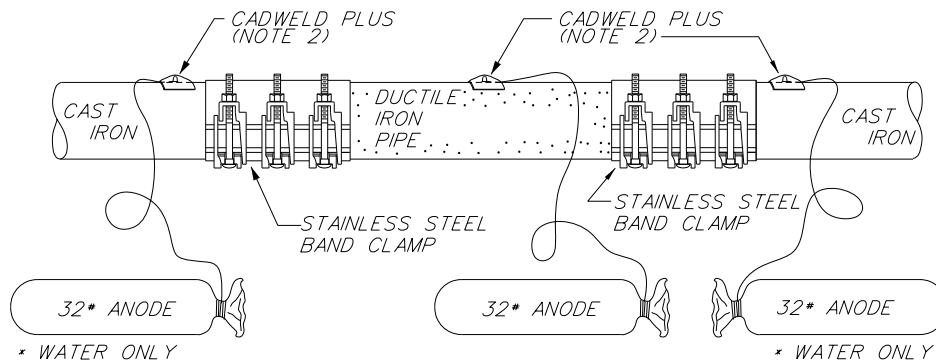

NOTE 1: STAINLESS STEEL BAND CLAMPS RANGE IN SIZE FROM 4" THRU 16". COUPLINGS SHOWN IN FIG 11 MAY BE USED FOR LARGER PIPE.

NOTE 2: INSTALL CADWELD PLUS AND COVER WELD AREA WITH PATCH-PAD EXOTHERMIC WELD PROTECTOR, BITUMASTIC COATING OR PRIMER AND COLD WRAP. CADWELD PLUS SHALL BE USED UNLESS FIELD CONDITIONS DO NOT ALLOW. CATHODI-CLAMP TO THEN BE USED WHEN NEEDED AND REQUIRES ENTIRE CIRCUMFERENCE OF PIPE TO BE EXPOSED.

### TEST POINT AND ANODE PLACEMENT FOR ISOLATED STEEL (SERVICES)

Whenever a main is relocated or replaced with another material, replacing any steel services which would become isolated due to the main project is always considered. Sometimes it is impractical to replace the steel service at that time. When this happens, an anode must be installed on the service according to [the chart on page 1 Table 1](#) and a test point established.

<b>METROPOLITAN UTILITIES DISTRICT</b>	<b>Construction Standard</b>	No: <b>8.3.1</b>
	<b>Magnesium Anode Placement &amp; Test Lead Detail (Gas &amp; Water)</b>	Page: 12 of 10 <del>Supersedes: 1-29-247- 29-25</del>
Prepared by: Rich Baird		Effective: <del>7-29-25</del>
Approved by: James Bartels	<del>The latest revisions can be found at the end of this document</del>	

The anode can be placed at any point on the service that is convenient to the installer. The test point may be established at the meter riser or in a valve box if one is available. See the [Records](#) section of this standard for documentation requirements.

**RECORDS**

The following ~~forms shall be filled out~~ documentation shall be gathered by the person that installed the anode and test point or by the person that directly supervised the installer. Refer to C.S. [12.1.0](#) for the proper form routing procedures.

To document any test point location, fill out the green [Form 1283-R1](#) and send to the Corrosion Engineer.

In addition to the corrosion forms, document as much information as possible about the test points, anode location, and size on leak reports, service cards, or as-built drawings.