

METROPOLITAN UTILITIES DISTRICT	Construction Standard	No: 3.0.1
	Typical Hydrant Installation and Abandonment for 6", 8", 12" and 16"	Page: 1 of 8
Prepared by: D.J. Satterfield	Water Mains	Supersedes: 12-4-18
Approved by: James Bartels		Effective: 5-10-23

The latest revisions can be found at the end of this document

GENERAL

This standard covers typical installation and relocation of hydrants off of 6", 8", 12", and 16" water mains.

NOTE: Obsolete fire hydrants shall not be reused. Refer to Construction Standard [3.1.1](#) for a list of obsolete fire hydrants.

LOCATION

Hydrants shall be located as shown on the drawings. In general, hydrants are located on or as near as possible to property lines. Hydrants shall not be placed closer than 10' from any sewer inlet or manhole, unless approved by the Engineer.

Hydrants shall be placed so they are completely accessible but placed as to minimize the possibility of damage from vehicles.

On streets with curbs, hydrants shall be set with the hydrant centerline three feet from the back of curb unless otherwise shown on the drawings. On cul-de-sacs the end-of-main hydrant shall be set at a location determined by the Engineer which will normally be 13'-0" back of curb.

If a hydrant is set between the curb and the sidewalk or between the sidewalk and the property line, it shall be placed so that no portion of the hydrant or nozzle cap shall be closer than six inches to the sidewalk.

INSTALLATION

All hydrants and valve boxes shall be plumb and hydrant outlets shall be level. Hydrants shall be set with the ground ring at ground level to no more than 2 inches above the finished grade. The finished grade for hydrants installed three feet back of curb shall be defined as the elevation of the top of curb adjacent to the hydrant. Finished grade for other hydrants will be determined by the Engineer.

- * An orange "Not in Service" identification tag or bag shall be placed and secured over each hydrant as the hydrant is installed. The preference is to utilize the identification tag. If a tag is not available, an alternative option is the identification bag. Identification tags shall be .050 thick UV stabilized polyethylene, bright orange in color and print clearly showing "NOT IN SERVICE". Acceptable tags are Assured Flow Sales, Inc. NIS tags. Identification bags shall be 4 mil. polypropylene material, bright orange in color and bold print clearly showing "NOT IN SERVICE". Tie straps shall be provided to firmly secure bags to hydrant. Acceptable bags are Assured Flow Sales, Inc. NIS bags.
- * The "Not in Service" tag or bag shall remain on the hydrant until the water main/hydrant has been placed into service. MUD Water Distribution crews shall remove the "Not in Service" tag or bag from public hydrants when the hydrant is placed into service.

Hydrants have a 5'-6" bury depth. If the main serving a hydrant is deeper or shallower than the bury depth of the hydrant, bends or offsets shall be used in the hydrant branch to bring the hydrant to proper grade.

- * Revised Text

METROPOLITAN UTILITIES DISTRICT	Construction Standard	No: 3.0.1
	Typical Hydrant Installation and Abandonment for 6”, 8”, 12” and 16” Water Mains	Page: 2 of 8
Prepared by: D.J. Satterfield		<u>Supersedes:</u> 12-4-18
Approved by: James Bartels		Effective: 5-10-23

The latest revisions can be found at the end of this document

Piping for hydrant branches, including air relief hydrants, shall be six inch in size and shall be either ductile iron or C900 PVC per MUD 110 or MUD 126, respectively. Piping material shall be per the enclosed drawings. Ductile iron piping and fittings shall be wrapped in polyethylene per Construction Standard [1.12.1](#). Fittings used on hydrant branches shall be per MUD 111. Type 1, Type 2, Type 3, Type 8, Type 9 and Type 10 hydrant branches shall be retained. Wedge action retainer glands shall be used to retain joints.

The lower barrel of the hydrant shall be wrapped in polyethylene per Construction Standard [1.12.1](#). The polyethylene wrap shall extend from the top of the flange on the hydrant shoe to a point 1” to 2” below grade. The polyethylene wrap shall be taped to the barrel at the termination points in a manner to prevent moisture from getting between the wrap and the hydrant barrel. **CAUTION: Do not extend the polyethylene wrap over the drain holes of the hydrant. Do not tape over the drain holes of the hydrant.**

Cast in place and precast concrete slabs shall be installed on PVC hydrant branches per the enclosed drawings. Polyethylene wrap on the barrel of the hydrant shall extend at least 4” above the top of the cast in place slab.

All hydrant branches shall be installed with the 4 ½” nozzle facing the street. All other hydrants will be faced by the District after the hydrant has been installed.

All hydrants shall have a 4" x 12" x 16" precast concrete settlement pad beneath them.

**

ABANDONMENT

An orange “Not in Service” identification tag or bag shall be placed and secured over each hydrant as the hydrant is abandoned. The preference is to utilize the identification tag. If a tag is not available, an alternative option is the identification bag. Identification tags shall be .050 thick UV stabilized polyethylene, bright orange in color and print clearly showing “NOT IN SERVICE”. Acceptable tags are Assured Flow Sales, Inc. NIS tags. Identification bags shall be 4 mil. polypropylene material, bright orange in color and bold print clearly showing “NOT IN SERVICE”. Tie straps shall be provided to firmly secure bags to hydrant. Acceptable bags are Assured Flow Sales, Inc. NIS bags.

The “Not in Service” tag or bag shall remain on the hydrant until the hydrant has been removed. MUD Water Distribution crews shall remove the “Not in Service” tag or bag from public hydrants when the hydrant is removed.

Abandoned hydrants should be removed in a timely manner.

RELOCATING A HYDRANT

End of Main Hydrants:

- End of main hydrants shall be relocated per the construction drawings.

** Added Section

METROPOLITAN UTILITIES DISTRICT	Construction Standard	No: 3.0.1
	Typical Hydrant Installation and Abandonment for 6", 8", 12" and 16" Water Mains	Page: 3 of 8
Prepared by: D.J. Satterfield		Supersedes: 12-4-18
Approved by: James Bartels		Effective: 5-10-23

The latest revisions can be found at the end of this document

Hydrant Branches:

- **WARNING:** *Prior to performing any relocation work on a hydrant branch, determine if the branch valve is retained to the branch tee. Do not dig behind the hydrant unless the main is depressurized or it is known that the branch valve is retained to the branch tee, the branch valve is closed, and the branch depressurized.*
- Cast iron hydrant branches shall be completely removed, including the branch tee, and replaced with a main size by six inch ductile iron tee, six inch valve and six inch ductile iron pipe unless otherwise specified. The hydrant shall be placed at the new location using appropriate fittings.
- Ductile iron hydrant branches shall have a valve retained to the branch tee. Existing valves that are not retained shall be retained using conventional methods which may include cutting out the tee and replacing it with a retained tee/valve combination. Relocate the hydrant with appropriate fittings.
- Hydrant branches shall be retained per Section C of this standard.

DRAINAGE

Drainage gravel shall be placed at the base of the hydrant as shown in the enclosed typical installation details to permit the barrel of the hydrant to drain. Hydrant drainage gravel shall be clean, washed, hard, durable, uncoated, and uniformly graded road gravel conforming to Nebraska Dept. of Roads standard specifications for highway construction. Gradation shall be as follows:

<u>Sieve Size</u>	<u>Percent Passing</u>
1"	100
#4	78±17
#10	15±15
#200	3±3

Hydrant drain holes shall be kept open and clean. Care should be exercised as to not block the drain holes with polyethylene wrap or concrete from backing blocks.

METROPOLITAN UTILITIES DISTRICT	Construction Standard	No: 3.0.1
	Typical Hydrant Installation and Abandonment for 6", 8", 12" and 16" Water Mains	Page: 5 of 8
Prepared by: D.J. Satterfield		<u>Supersedes:</u> 12-4-18
Approved by: James Bartels		Effective: 5-10-23

The latest revisions can be found at the end of this document

TYPICAL HYDRANT INSTALLATIONS

TYPE 3

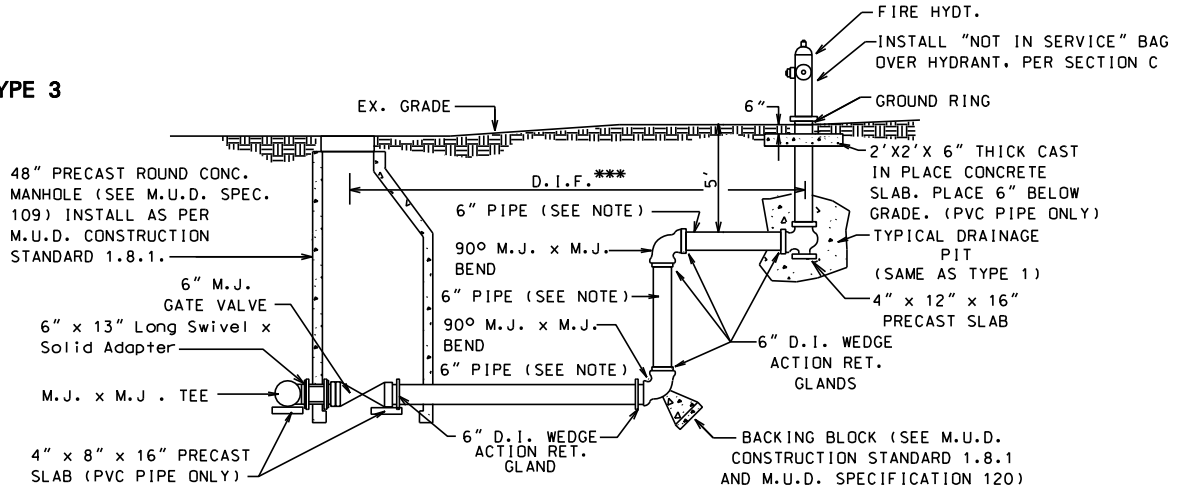

NOTE: PIPE SHALL BE D.I. IF MAIN IS D.I. OR C900 PVC IF MAIN IS PVC.

*** DETERMINE IN FIELD

DEEP STANDARD BRANCH (≥7' OF COVER)

TYPE 4

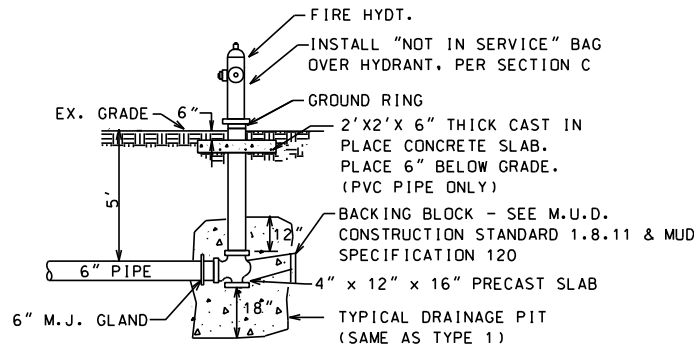

END OF MAIN

TYPE 5

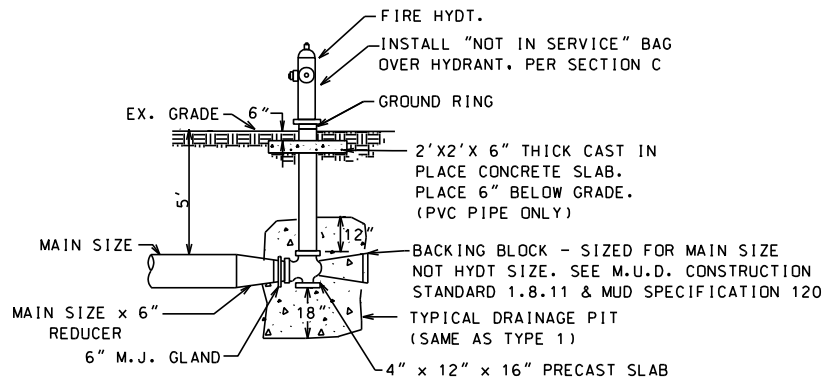

END OF MAIN WITH REDUCER

METROPOLITAN UTILITIES DISTRICT	Construction Standard	No: 3.0.1
	Typical Hydrant Installation and Abandonment for 6", 8", 12" and 16" Water Mains	Page: 6 of 8
Prepared by: D.J. Satterfield		<u>Supersedes:</u> 12-4-18
Approved by: James Bartels		Effective: 5-10-23

The latest revisions can be found at the end of this document

TYPICAL HYDRANT INSTALLATIONS

TYPE 6

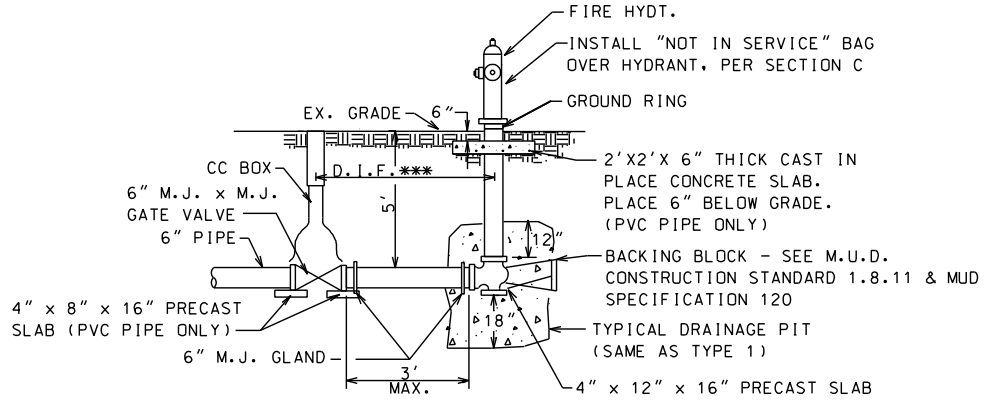

*** DETERMINE IN FIELD

END OF MAIN WITH VALVE

TYPE 7

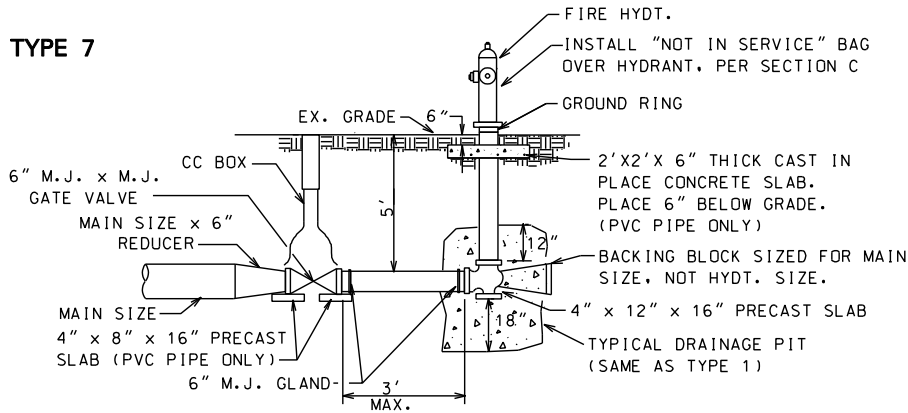

**END OF MAIN WITH
REDUCER AND VALVE**

METROPOLITAN UTILITIES DISTRICT	Construction Standard	No: 3.0.1
	Typical Hydrant Installation and Abandonment for 6", 8", 12" and 16"	Page: 7 of 8
Prepared by: D.J. Satterfield	Water Mains	<u>Supersedes:</u> 12-4-18
Approved by: James Bartels		Effective: 5-10-23

The latest revisions can be found at the end of this document

TYPICAL HYDRANT INSTALLATIONS

TYPE 8

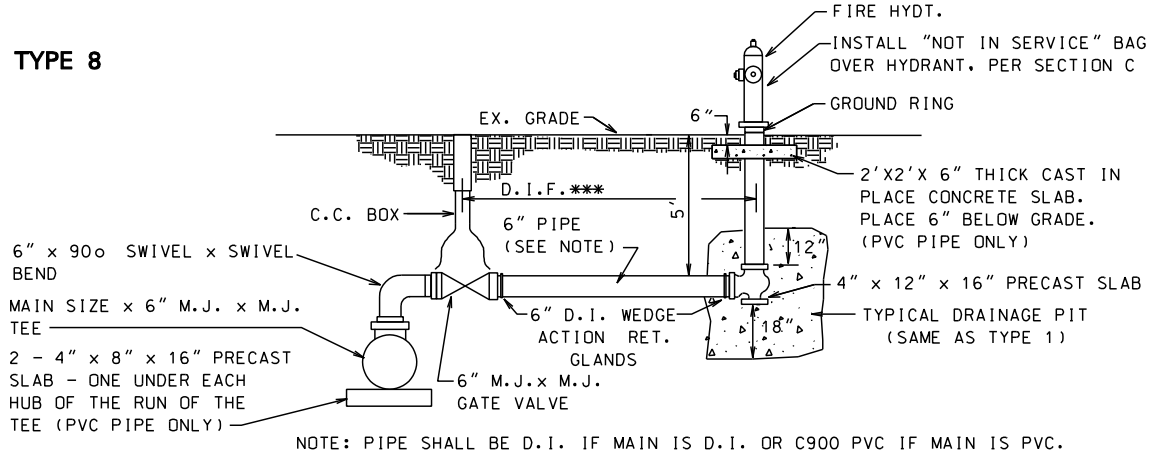

*** DETERMINE IN FIELD

AIR RELIEF HYDT. (PER DRAWING OR AS DIRECTED BY ENGINEER ONLY)

TYPE 9

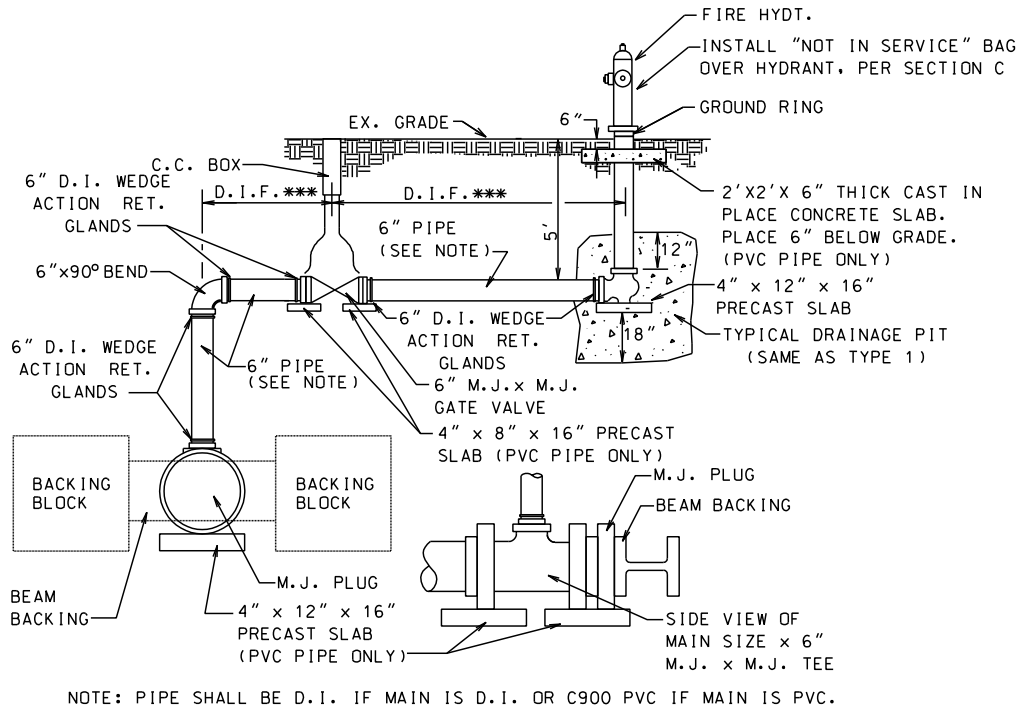

*** DETERMINE IN FIELD

END OF DEEP 12" AND 16" MAINS (PER DRAWING OR AS DIRECTED BY ENGINEER ONLY)

METROPOLITAN UTILITIES DISTRICT	Construction Standard	No: 3.0.1
	Typical Hydrant Installation and Abandonment for 6", 8", 12" and 16" Water Mains	Page: 8 of 8
Prepared by: D.J. Satterfield		<u>Supersedes:</u> 12-4-18
Approved by: James Bartels		Effective: 5-10-23

The latest revisions can be found at the end of this document

TYPICAL HYDRANT INSTALLATION

TYPE 10

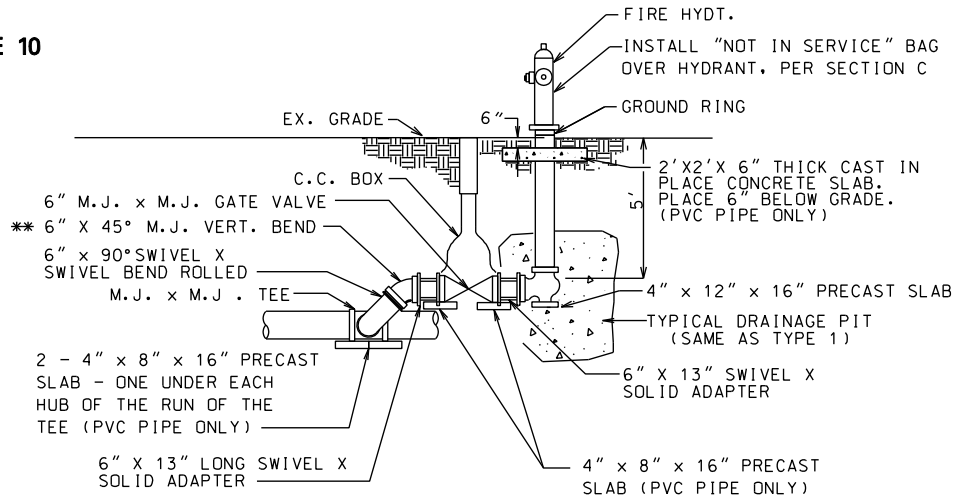

DEEP PARALLEL BRANCH

(PER DRAWING OR AS DIRECTED BY ENGINEER ONLY)

** USE DIFFERENT DEGREE BENDS
AS NEEDED TO ADJUST FOR GRADE.

Revision

The latest revision is detailed on the following page(s).

Pages affected: #1 & #2

GENERAL

This standard covers typical installation and relocation of hydrants off of 6", 8", 12", and 16" water mains.

NOTE: Obsolete fire hydrants shall not be reused. Refer to Construction Standard [3.1.1](#) for a list of obsolete fire hydrants.

LOCATION

Hydrants shall be located as shown on the drawings. In general, hydrants are located on or as near as possible to property lines. Hydrants shall not be placed closer than 10' from any sewer inlet or manhole, unless approved by the Engineer.

Hydrants shall be placed so they are completely accessible but placed as to minimize the possibility of damage from vehicles.

On streets with curbs, hydrants shall be set with the hydrant centerline three feet from the back of curb unless otherwise shown on the drawings. On cul-de-sacs the end-of-main hydrant shall be set at a location determined by the Engineer which will normally be 13'-0" back of curb.

If a hydrant is set between the curb and the sidewalk or between the sidewalk and the property line, it shall be placed so that no portion of the hydrant or nozzle cap shall be closer than six inches to the sidewalk.

INSTALLATION

All hydrants and valve boxes shall be plumb and hydrant outlets shall be level. Hydrants shall be set with the ground ring at ground level to no more than 2 inches above the finished grade. The finished grade for hydrants installed three feet back of curb shall be defined as the elevation of the top of curb adjacent to the hydrant. Finished grade for other hydrants will be determined by the Engineer.

* An orange "Not in Service" identification tag or bag shall be placed and secured over each hydrant as the hydrant is installed. **The preference is to utilize the identification tag. If a tag is not available, an alternative option is the identification bag. Identification tags shall be .050 thick UV stabilized polyethylene, bright orange in color and print clearly showing "NOT IN SERVICE". Acceptable tags are Assured Flow Sales, Inc. NIS tags.** Identification bags shall be 4 mil. polypropylene material, bright orange in color and bold print clearly showing "NOT IN SERVICE". Tie straps shall be provided to firmly secure bags to hydrant. Acceptable bags are Assured Flow Sales, Inc. NIS bags.

* The "Not in Service" tag or bag shall remain on the hydrant until the water main/hydrant has been placed into service. MUD Water Distribution crews shall remove the "Not in Service" tag or bag from public hydrants when the hydrant is placed into service.

Hydrants have a 5'-6" bury depth. If the main serving a hydrant is deeper or shallower than the bury depth of the hydrant, bends or offsets shall be used in the hydrant branch to bring the hydrant to proper grade.

* Revised Text

Piping for hydrant branches, including air relief hydrants, shall be six inch in size and shall be either ductile iron or C900 PVC per MUD 110 or MUD 126, respectively. Piping material shall be per the enclosed drawings. Ductile iron piping and fittings shall be wrapped in polyethylene per Construction Standard [1.12.1](#). Fittings used on hydrant branches shall be per MUD 111. Type 1, Type 2, Type 3, Type 8, Type 9 and Type 10 hydrant branches shall be retained. Wedge action retainer glands shall be used to retain joints.

The lower barrel of the hydrant shall be wrapped in polyethylene per Construction Standard [1.12.1](#). The polyethylene wrap shall extend from the top of the flange on the hydrant shoe to a point 1” to 2” below grade. The polyethylene wrap shall be taped to the barrel at the termination points in a manner to prevent moisture from getting between the wrap and the hydrant barrel. **CAUTION:** *Do not extend the polyethylene wrap over the drain holes of the hydrant. Do not tape over the drain holes of the hydrant.*

Cast in place and precast concrete slabs shall be installed on PVC hydrant branches per the enclosed drawings. Polyethylene wrap on the barrel of the hydrant shall extend at least 4” above the top of the cast in place slab.

All hydrant branches shall be installed with the 4 ½” nozzle facing the street. All other hydrants will be faced by the District after the hydrant has been installed.

All hydrants shall have a 4" x 12" x 16" precast concrete settlement pad beneath them.

**

ABANDONMENT

An orange “Not in Service” identification tag or bag shall be placed and secured over each hydrant as the hydrant is abandoned. The preference is to utilize the identification tag. If a tag is not available, an alternative option is the identification bag. Identification tags shall be .050 thick UV stabilized polyethylene, bright orange in color and print clearly showing “NOT IN SERVICE”. Acceptable tags are Assured Flow Sales, Inc. NIS tags. Identification bags shall be 4 mil. polypropylene material, bright orange in color and bold print clearly showing “NOT IN SERVICE”. Tie straps shall be provided to firmly secure bags to hydrant. Acceptable bags are Assured Flow Sales, Inc. NIS bags.

The “Not in Service” tag or bag shall remain on the hydrant until the hydrant has been removed. MUD Water Distribution crews shall remove the “Not in Service” tag or bag from public hydrants when the hydrant is removed.

Abandoned hydrants should be removed in a timely manner.

RELOCATING A HYDRANT

End of Main Hydrants:

- End of main hydrants shall be relocated per the construction drawings.

** Added Section