

METROPOLITAN UTILITIES DISTRICT	O & M Procedure	No: E.227.0
Prepared by: Bill Travnicsek	Qualification of Pipeline Welders	Page: 1 of 10
Approved: Ron Reisner		<u>Supersedes:</u> 9-19-08
		Effective: 11-30-09

I. GENERAL

* Before any District or contract welder may weld on the Metropolitan Utilities District gas distribution and transmission system piping and facilities, the welder shall be qualified to perform the District's applicable qualified written welding procedure(s). To weld on District gas piping using the shielded metal-arc welding process and/or the gas metal-arc welding process, the welder shall be qualified on procedure [E.225.2](#), "Welding Procedure – Shielded Metal-Arc" and/or procedure [E.225.3](#), "Welding Procedure – Gas Metal-Arc", according to API 1104, section 6.3, Twentieth Edition. If qualifying on X-52 pipe, procedure [E.225.5](#), "Welding Procedure – Shielded Metal Arc Welding (SMAW) On Grade X-52 Pipe" and procedure [E.225.6](#), "Welding Procedure – Gas Metal Arc Welding (GMAW) On Grade X-52 Pipe" shall be followed. Qualification on procedure [E.225.4](#), "Welding Procedure - Oxy-Acetylene" shall be according to [Appendix C](#) of the Minimum Federal Safety Standards, Part 192. Review procedure [E.227.1](#) for qualification of Field Service welders.

II. DISTRICT WELDING PROCESSES

- A. Shielded Metal-Arc Welding:** Shielded metal-arc welding (SMAW) uses a covered electrode consisting of a core wire with a baked covering of a clay-like mixture of silicate binders and powdered materials. This covering is a source of arc stabilizers, gases to displace air, metal and slag to protect, support, and insulate the hot weld metal. Welders using the shielded metal-arc welding (SMAW) process shall weld according to welding procedure [E.225.2](#) or procedure [E.225.5](#) if welding using X-52 pipe. The welder shall pay particular attention to the essential variables, marked with a double asterisk (**), and weld accordingly. The welder shall weld downhill in the fixed position.
- B. Gas Metal-Arc Welding:** Gas metal-arc welding (GMAW) uses a continuous solid wire or tubular electrode to provide filler metal and uses gas to shield the arc and weld metal. Welders using the gas metal-arc welding (GMAW) process shall weld according to welding procedure [E.225.3](#) or procedure [E.225.6](#) if welding using X-52 pipe. The welder shall pay particular attention to the essential variables, marked with a double asterisk (**), and weld accordingly. The welder shall weld downhill in the fixed position.
- C. Oxy-acetylene:** Oxy-acetylene mixes oxygen and acetylene fuel to produce a flame hot enough to melt the base material and the filler material to form the weld. Welders using the oxy-acetylene welding process shall weld according to welding procedure [E.225.4](#). The welder shall pay particular attention to the essential variables, marked with a double asterisk (**), and weld accordingly. The welder shall weld downhill in the fixed position.

**

* Revised Text

** Removed Text

METROPOLITAN UTILITIES DISTRICT	O & M Procedure	No: E.227.0
Prepared by: Bill Travnicsek	Qualification of Pipeline Welders	Page: 2 of 10
Approved: Ron Reisner		Supersedes: 9-19-08
		Effective: 11-30-09

III. WELDER QUALIFICATION TESTS

- * The pipeline welders shall initially qualify to use shielded metal-arc welding (SMAW) according to API 1104, section 6.3, Option 1 - "Multiple Qualification" or Option 2 - "Single Qualification". If the pipeline welders are to also qualify using the gas metal arc welding (GMAW) process, they shall test in the same manner as for SMAW.

A. Option 1 - Multiple Qualification Tests Using Shielded and Gas Metal Arc Welding

- * Multiple Qualification requires the pipeline welders to successfully complete the two tests described below, following the District's qualified weld procedures.

- * *1st test* - the welder shall perform a butt weld, according to welding procedure [E.225.2](#) for SMAW and [E.225.3](#) for GMAW or procedure [E.225.5](#) for SMAW and [E.225.6](#) for GMAW if testing on X-52 pipe, in the fixed position with the axis of the pipe either in the horizontal plane or inclined from the horizontal plane at an angle of not more than 45°. The butt weld shall be made on pipe with an outside diameter of at least 12.750 inches and with a nominal wall thickness of 0.250 inches without a backing strip. E-6010 or E-7010 electrodes may be used.

- * *2nd test* - the welder shall lay out, cut, fit, and weld a full-sized branch-on-pipe connection according to welding procedure [E.225.2](#) for SMAW and [E.225.3](#) for GMAW or procedure [E.225.5](#) for SMAW and [E.225.6](#) for GMAW if testing on X-52 pipe. The weld shall be made on a pipe with a diameter of at least 12.750 inches and with a nominal wall thickness of 0.250 inches. A full-size hole shall be cut in the run-pipe and the branch-pipe fitted to the opening. The weld shall be made with the run-pipe axis in the horizontal position and the branch-pipe axis extending vertically downward from the run. If the welder uses E-6010 or E-7010 electrodes for the full branch, the coupon, that was cut out during the full branch fit up, must be welded as a patch somewhere on the side using E-7018 electrodes. If the branch is welded with E-7018 electrodes, the coupon is not required to be welded as a patch on the side.

B. Option 2 - Single Qualification Tests Using Shielded and Gas Metal Arc Welding

- * Single Qualification requires the pipeline welders to successfully complete the two tests described below, following the District's qualified weld procedures.

- * *1st test* - the welder shall perform three (3) butt welds according to welding procedure [E.225.2](#) for SMAW and [E.225.3](#) for GMAW or procedure [E.225.5](#) for SMAW and [E.225.6](#) for GMAW if testing on X-52 pipe, in the fixed position with the axis of the pipe either in the horizontal plane or inclined from the horizontal plane at an angle of not more than 45°. A butt weld shall be made on each of the following pipe sizes. Less than 0.188" wall on the 1-1/4" pipe, 0.188" wall on the 4" pipe and 0.25" wall on the 16" pipe.

- * *2nd test* - the welder shall make a lap fillet weld on a 2" pipe inserted into a heavy wall 2-1/2" pipe according to welding procedure [E.225.2](#) for SMAW and [E.225.3](#) for GMAW or procedure [E.225.5](#) for SMAW and [E.225.6](#) for GMAW if testing on X-52 pipe.

METROPOLITAN UTILITIES DISTRICT	O & M Procedure	No: E.227.0
Prepared by: Bill Travnicsek	Qualification of Pipeline Welders	Page: 3 of 10
Approved: Ron Reisner		<u>Supersedes:</u> 9-19-08
		Effective: 11-30-09

* Revised Text

* **C. Oxy-acetylene Welder Qualification Tests**

The pipeline welders shall qualify to use oxy-acetylene welding according to [Appendix C](#) of CFR part 192. The welder shall make one butt-weld in the fixed position with the axis of the pipe in the horizontal plane. The butt-weld shall be made on pipe having a nominal diameter of 2 inches and a nominal wall thickness of 0.154 inches. The welder shall make the weld in accordance with procedure [E.225.4](#).

IV. TESTING THE QUALIFYING WELDS

* The District's Chief Welder shall be tested and qualified by an individual or company qualified and approved by the District. All other District and contract welders may be tested and qualified by the District's Chief Welder.

A. Shielded and Gas Metal-Arc Welding

* All qualification test welds performed under shielded (SMAW) or gas (GMAW) metal-arc welding processes must meet the requirements of sections 6.4 (Visual Examination) and either 6.5 (Destructive Testing) or 6.6 (Radiography-Butt Welds Only) of the 20th Edition of API 1104. All qualification test welds performed under the oxy-acetylene welding process must meet the requirements of [Appendix C](#) of the Minimum Federal Safety Standards, Part 192.

1. Visual Examination (butt-welds and branch welds)

The weld shall be free from cracks, inadequate penetration, and burn-through, and must present a neat workman-like appearance. The depth of undercutting adjacent to the final bead on the outside of the pipe shall not be more than 1/32 in. or 12.5% of the pipe wall thickness, whichever is smaller, and there shall not be more than 2 in. of undercutting in any continuous 12-in. length of weld.

2. Destructive Testing (butt-weld)

* Option 1, Multiple Qualification - The butt-weld test specimens shall be cut from the 12" pipe as shown in Fig 1.

* Option 2 Single Qualification - The butt-weld test specimens shall be cut from the 1-1/4", 4" and 16" pipe as shown in Fig 1A.

* Revised Text

**

REMOVAL OF TEST SPECIMENS
FROM 12" PIPE FOR MULTIPLE
QUALIFICATION

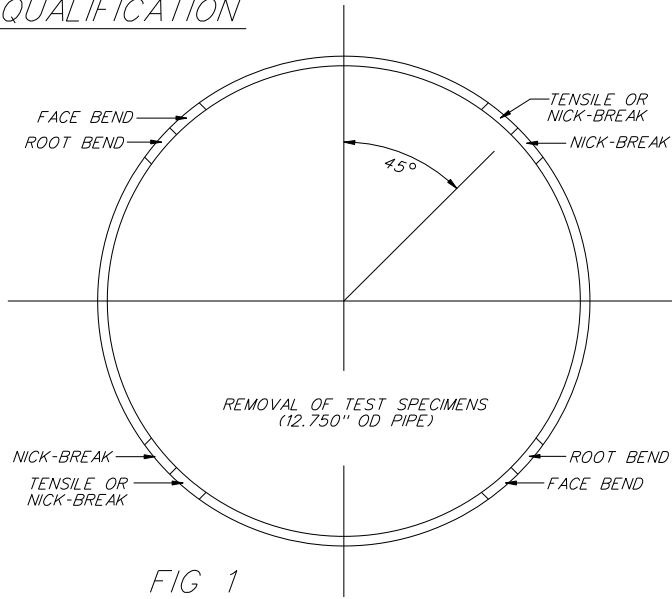

REMOVAL OF TEST SPECIMENS
FROM 1-1/4", 4" AND 16" PIPE
FOR SINGLE QUALIFICATION

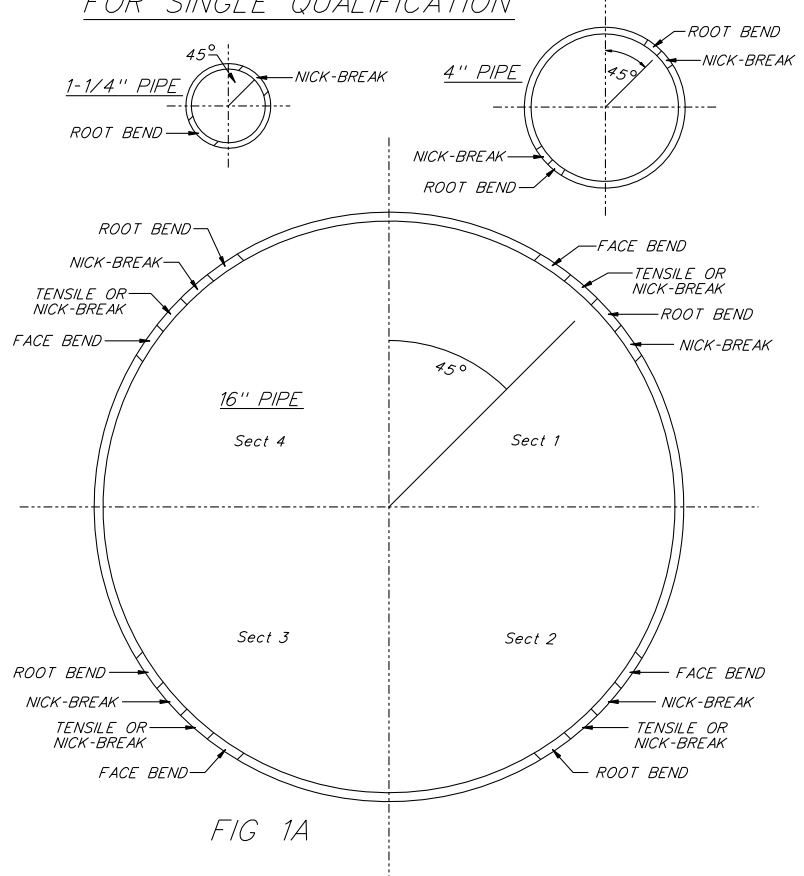

FIG 1

FIG 1A

Tensile Test (butt-weld) – the tensile test specimens shall be approximately 9 in. long and approximately 1 in. wide. They may be machine cut or oxygen cut, and the sides (edges) must be smooth and parallel. The weld reinforcement on the inside and outside should not be removed. See Fig 2. The tensile-strength test specimens shall be broken under tensile load using equipment capable of measuring the load at which failure occurs. If any specimen breaks in the weld or fusion zone and the observed strength is less than the specified minimum yield strength of the pipe, the weld shall be disqualified.

TENSILE TEST SPECIMEN

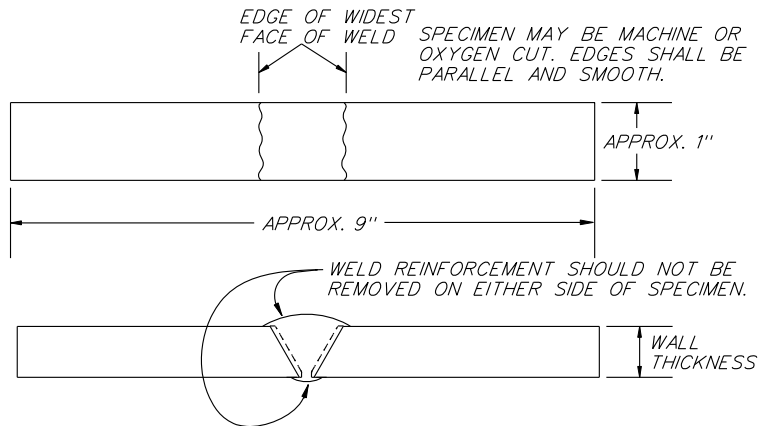
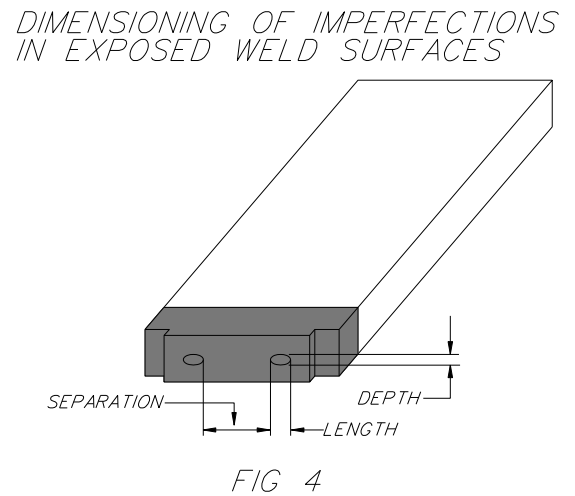
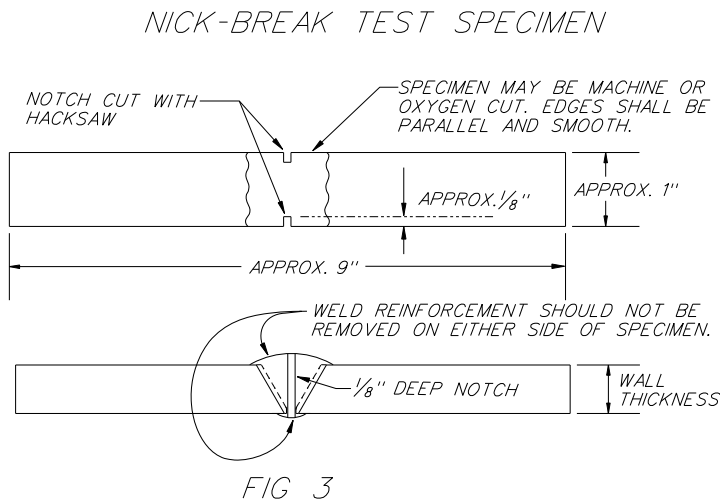

FIG 2

METROPOLITAN UTILITIES DISTRICT	O & M Procedure	No: E.227.0
	Prepared by: Bill Travnicsek	Page: 5 of 10
Approved: Ron Reisner	Qualification of Pipeline Welders	Supersedes: 9-19-08
		Effective: 11-30-09

** Revised Drawing

Nick-Break Test (butt-weld) - the nick-break test specimens shall be approximately 9 in. long and approximately 1 in. wide. They may be machine cut or oxygen cut, and the sides (edges) must be smooth and parallel. The weld reinforcement on the inside and outside should not be removed. They shall be notched with a hacksaw on each side at the center of the weld, and each notch shall be approximately 1/8 inch deep. Refer to Fig 3. The nick-break specimens shall be broken by pulling in a tensile machine, by supporting the ends and striking the center, or by supporting one end and striking the other end with a hammer. The exposed area of the fracture shall be at least 3/4 inch wide. The exposed area of each nick-break specimen shall show complete penetration and fusion. The greatest dimension of any gas pocket shall not exceed 1/16 inch and the combined area of all gas pockets shall not exceed 2% of the exposed surface area. Slag inclusions shall not be more than 1/32 inch in depth and shall not be more than one-half the wall thickness in length. There shall be at least 1/2 inch separation between adjacent slag inclusions. The dimensions should be measured as shown in Fig 4.



Root and Face Bend Test (butt-weld) - the root and face bend test specimens shall be approximately 9 in. long and approximately 1 in. wide, and their long edges shall be rounded. They may be machine cut or oxygen cut, and the sides (edges) must be smooth and parallel. The cover and root weld reinforcements shall be removed flush with the pipe surface. These surfaces shall be smooth and any scratches that exist shall be light and transverse to the weld. See Fig 5. The root and face bend specimens shall be bent in a guided-bend jig similar to that shown in Fig 6. Each specimen shall be placed on the die with the weld at mid span. Face-bend specimens shall be placed with the face of the weld toward the gap, and root-bend specimens shall be placed with the root of the weld toward the gap. The plunger shall be forced onto the gap until the curvature of the specimen is approximately U-shaped. The bend test shall be considered acceptable if no crack or other imperfection exceeding one-half the wall thickness in any direction is present in the weld or between the weld and the fusion zone after bending. Cracks that originate on the outer radius of the bend along the edges of the specimen during testing and that are less than 1/4 inch, measured in any direction, shall not be

METROPOLITAN UTILITIES DISTRICT	O & M Procedure	No: E.227.0
Prepared by: Bill Travnicek	Qualification of Pipeline Welders	Page: 6 of 10
Approved: Ron Reisner		Supersedes: 9-19-08
		Effective: 11-30-09

considered unless obvious imperfections are observed. Each specimen subjected to the bend test shall, meet these requirements.

FACE AND ROOT-BEND SPECIMEN

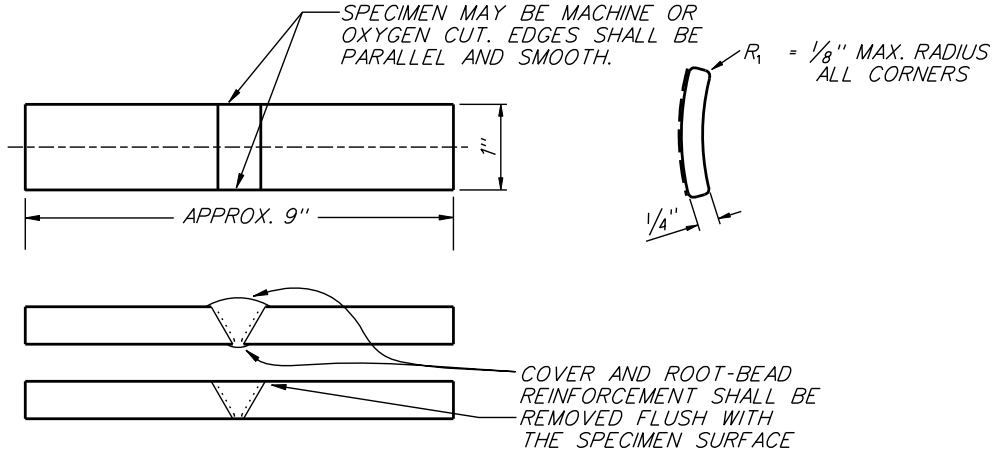

FIG 5
GUIDED - BEND TEST JIG
A.P.I. STANDARD

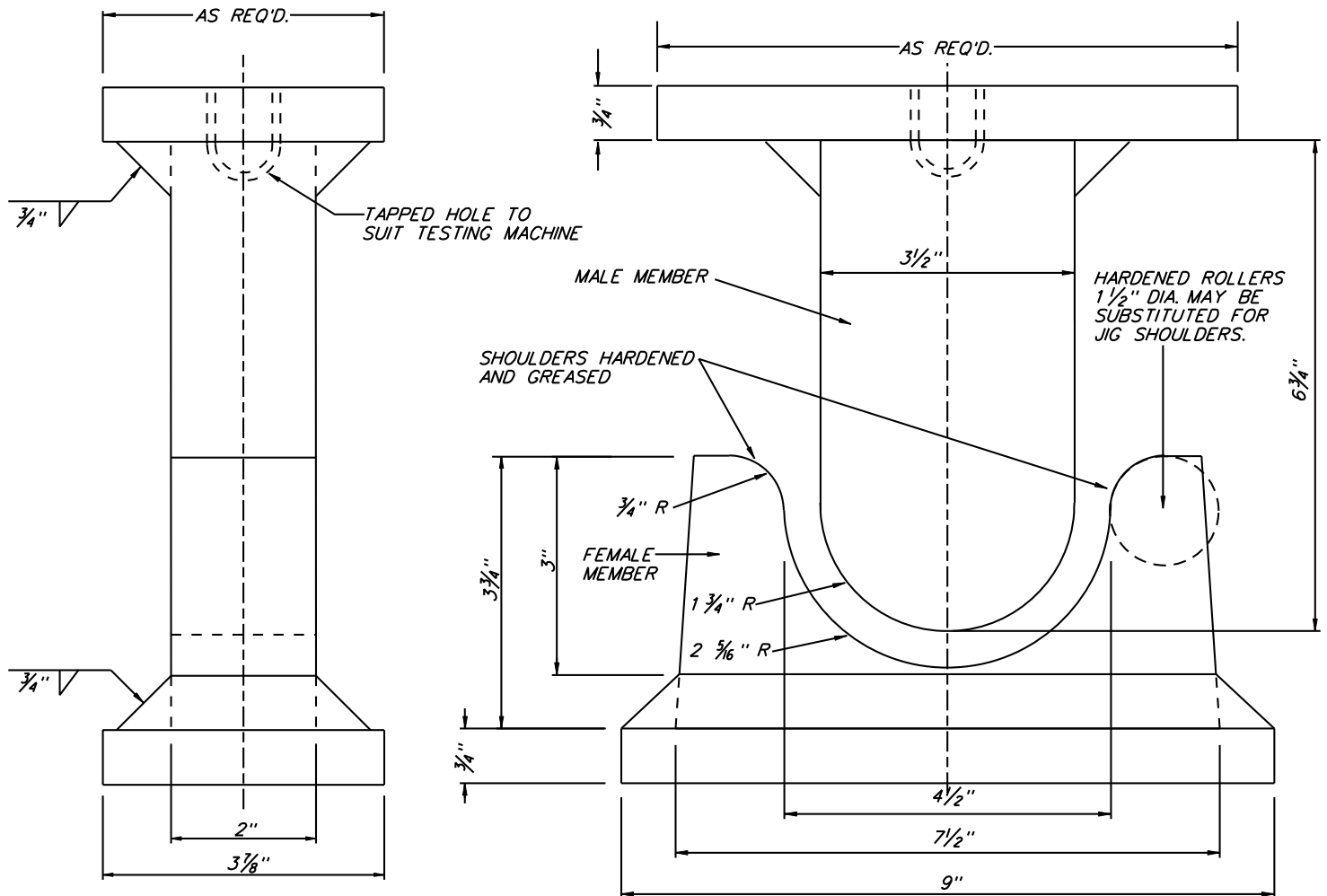

FIG 6

METROPOLITAN UTILITIES DISTRICT	O & M Procedure	No: E.227.0
Prepared by: Bill Travnicsek	Qualification of Pipeline Welders	Page: 8 of 10
Approved: Ron Reisner		Supersedes: 9-19-08
		Effective: 11-30-09

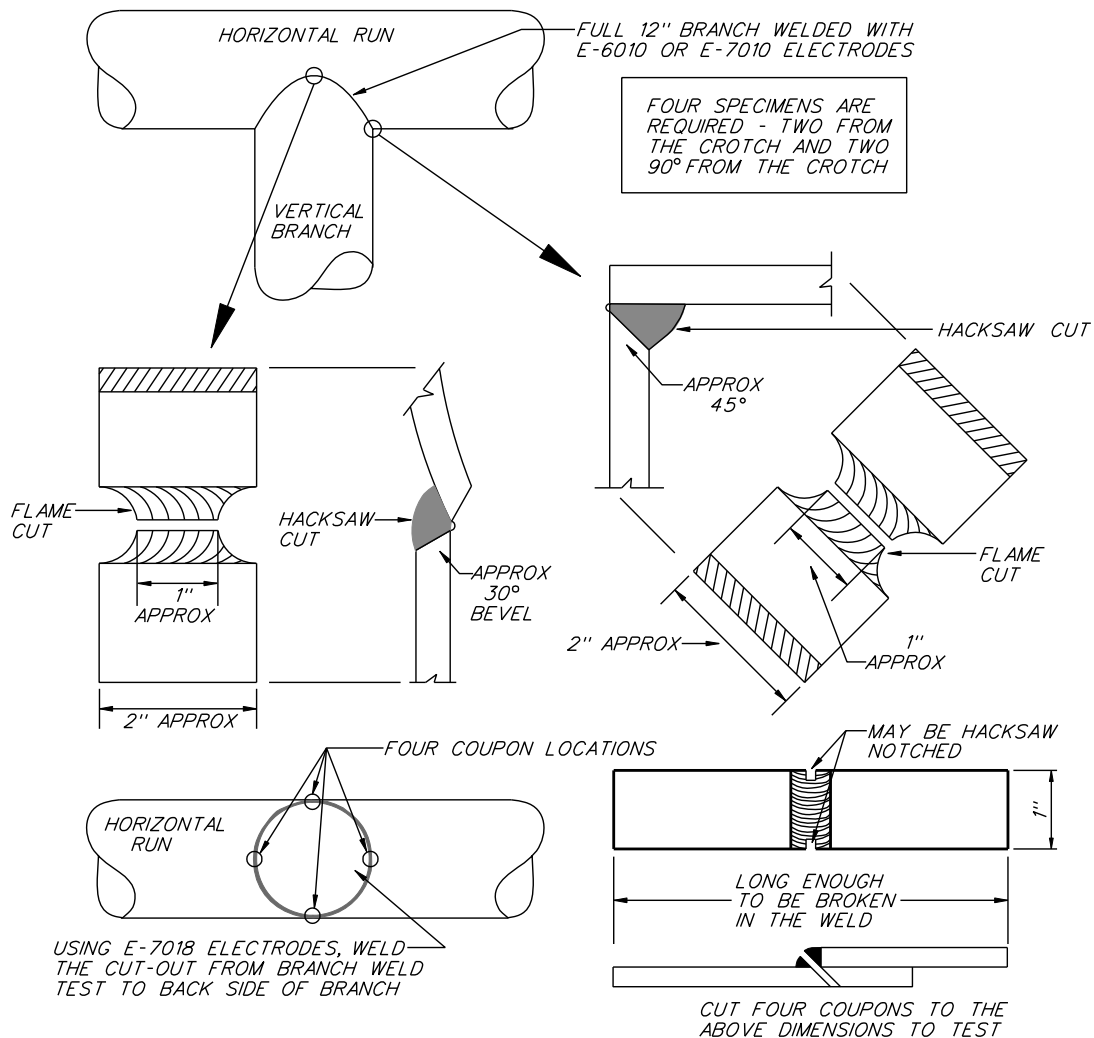

FIG 7

3. Destructive Testing Fillet Weld

* **Option 1 Multiple Qualification** - To test the fillet-welded joint (branch weld), four test specimens shall be cut from the test weld. Two from the crotch and two 90° from the crotch. See Fig 7. The specimens may be machine cut or oxygen cut. They should be at least 1 inch wide and long enough so that they can be broken in the weld. The fillet welds may be broken in the weld by any convenient method. The exposed surfaces of each fillet-weld specimen shall show complete penetration and fusion. The greatest dimension of any gas pocket shall not exceed 1/16 inch. The combined area of all gas pockets shall not exceed 2% of the exposed surface area. Slag inclusions shall not be more than 1/32 inch in depth and shall not be more than one-half the nominal wall thickness in length. There shall be at least 1/2 inch separation between adjacent slag inclusions. **Note:** If the welder uses E-6010 or E-7010 electrodes for the full branch, the cut-out coupon must be welded as a patch somewhere on the side using E-7018 electrodes and tested as shown in Fig 7. If the full branch is welded with E-7018 electrodes, the coupon is not required to be welded and tested.

METROPOLITAN UTILITIES DISTRICT Prepared by: Bill Travnicek Approved: Ron Reisner	O & M Procedure	No: E.227.0
	Qualification of Pipeline Welders	Page: 9 of 10
		Supersedes: 9-19-08
		Effective: 11-30-09

** Revised Drawing

**

*

Option 2 Single Qualification - To test the fillet-welded lap joint, four test specimens shall be cut from the test weld from the locations shown in Fig 8. The specimens may be machine cut or oxygen cut. They should be at least 1 inch wide and long enough so that they can be broken in the weld. The fillet welds may be broken in the weld by any convenient method. The exposed surfaces of each fillet-weld specimen shall show complete penetration and fusion. The greatest dimension of any gas pocket shall not exceed 1/16 inch. The combined area of all gas pockets shall not exceed 2% of the exposed surface area. Slag inclusions shall not be more than 1/32 inch in depth and shall not be more than one-half the nominal wall thickness in length. There shall be at least 1/2 inch separation between adjacent slag inclusions.

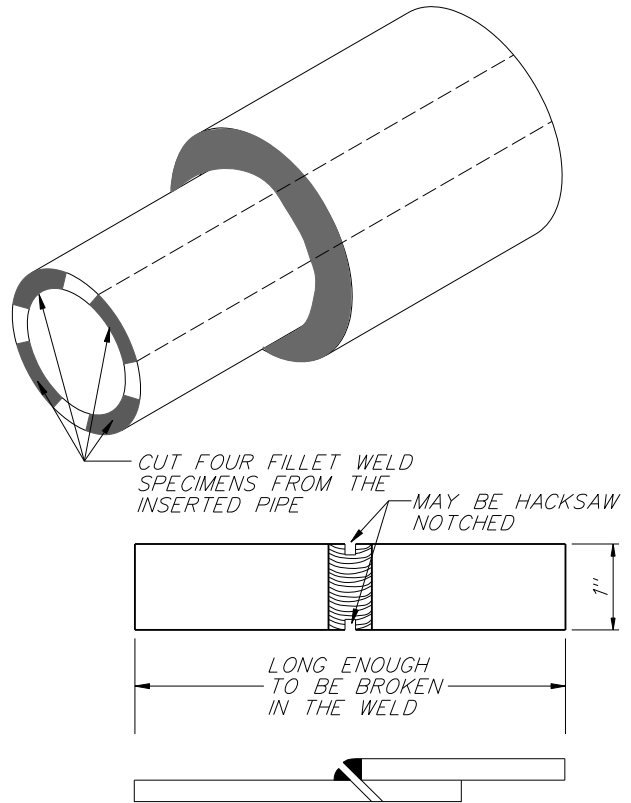

FIG 8

B. Oxy-acetylene Welding

1. Destructive Testing (butt-weld)

*

Upon completion, the test weld is cut into four coupons and subjected to a root bend test. Refer to Fig 9. If, as a result of this test, two or more of the four coupons develop a crack in the weld material, or between the weld material and base metal, that is more than 1/8 inch long in any direction, the weld is unacceptable. Cracks that occur on the corner of the specimen during testing are not considered.

REMOVAL OF TEST SPECIMENS 2" PIPE

ROOT-BEND SPECIMEN

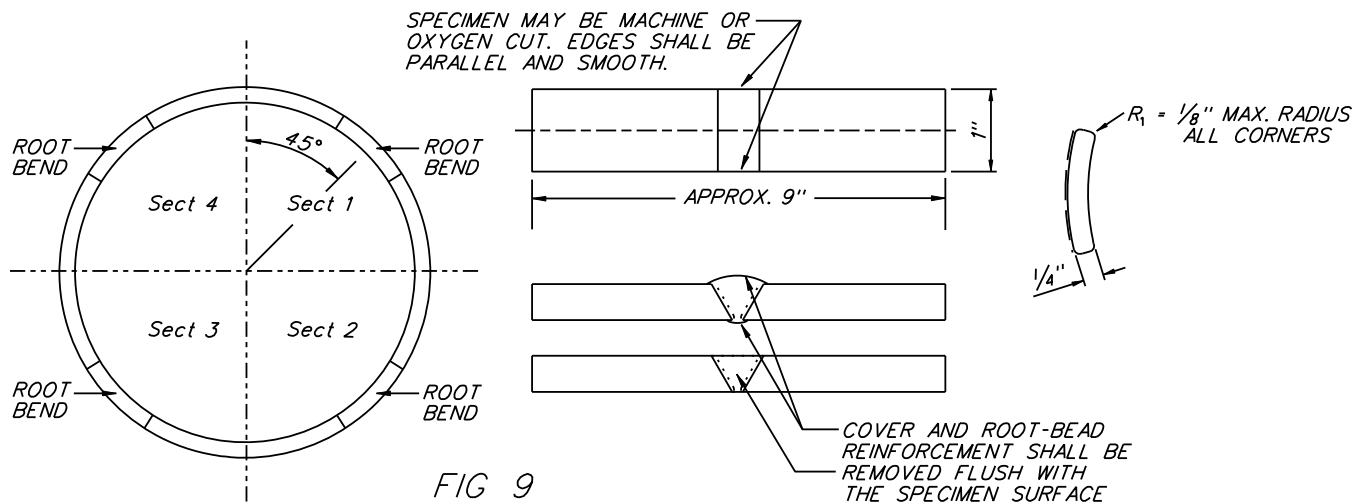

FIG 9

METROPOLITAN UTILITIES DISTRICT	O & M Procedure	No: E.227.0
Prepared by: Bill Travnicsek	Qualification of Pipeline Welders	Page: 10 of 10
Approved: Ron Reisner		Supersedes: 9-19-08
		Effective: 11-30-09

* Revised Text

** New Drawing

V. RETESTS

A welder who fails to meet the minimum requirements for one or more of the test procedures prescribed may, at the District's option, be retested. The welder shall make an acceptable test weld for each position on which he has failed prior to welding on District mains.

VI. QUALIFICATION

A. Metal Arc Welding

Qualifying Under Option 1 Multiple Qualification: Satisfactory completion of the required tests shall qualify the welder to weld in all positions; on all wall thickness, joint designs, and fittings; all pressures; and on all pipe diameters. If any of the following essential variables are changed in a procedure specification, the welder using the changed procedure shall be re-qualified:

- * 1. Change in welding process or combination of welding processes (Defined in Section II). Example: If our procedure requires a butt-weld to be made using the shielded metal arc process and we decide to perform the root pass using the gas metal arc process and perform the fill and cap passes using the shielded metal arc process, the procedure and welder must be re-qualified.
- 2. Change in direction of welding from vertical uphill to vertical downhill, or vice versa.
- * 3. Change in filler metal classification from group 1 or 2 to group 3 or from group 3 to group 1 or group 2. See Table 1 in Section 5.4 of API 1104, Twentieth Edition.

* **Qualifying Under Option 2 Single Qualification:** Satisfactory completion of the required tests shall qualify the welder to weld on all wall thickness up to 0.750", all pressures, and all pipe diameters. If any of the following essential variables are changed in a procedure specification, the welder using the changed procedure shall be re-qualified:

- * 1. Change in welding process or combination of welding processes (Defined in Section II). Example: If our procedure requires a butt-weld to be made using the shielded metal arc process and we decide to perform the root pass using the gas metal arc process and perform the fill and cap passes using the shielded metal arc process, the procedure and welder must be re-qualified.
- 2. Change in direction of welding from vertical uphill to vertical downhill, or vice versa.
- * 3. Change in filler metal classification from group 1 or 2 to group 3 or from group 3 to group 1 or group 2. See Table 1 in Section 5.4 of API 1104, Twentieth Edition.
- 4. Change to wall thickness greater than 0.750"

* Revised Text

METROPOLITAN UTILITIES DISTRICT	O & M Procedure	No: E.227.0
Prepared by: Bill Travnicsek	Qualification of Pipeline Welders	Page: 11 of 10
Approved: Ron Reisner		<u>Supersedes:</u> 9-19-08
		Effective: 11-30-09

5. A change in position from that for which the welder has already qualified (for example, a change from rolled to fixed or a change from vertical to horizontal or vice versa). A welder who successfully passes a butt-weld qualification test in the fixed position with the axis inclined 45° from the horizontal plane shall be qualified to do butt welds and lap fillet welds in all positions.
6. A change in joint design such as V-bevel to U-bevel.

* If any of the other essential variables change, the welder may not have to be re-qualified but the procedure may have to be re-qualified. Review API 1104, Twentieth Edition.

B. Oxy-acetylene Welding: Satisfactory completion of the required tests shall qualify the welder to weld on District mains and piping up to and including 2-3/8 inch outside diameter with nominal wall thickness less than 0.188 inch. Service line connections and fillet welds are not to be oxy-acetylene welded.

VII. RE-QUALIFICATION

No welder may weld with a particular welding process unless, within the preceding 6 calendar months he has engaged in welding with that process.

* **A. Shielded and Gas Metal-Arc Welding -** The welder will remain qualified if one 6", 8" or 12" butt-weld is tested every six months, not to exceed 7 ½ months, but at least twice each calendar year. If the 7 ½ month period is exceeded, the welder will have to re-qualify by performing the initial qualifying test described in Section III, A or Section III, B of this procedure.

B. Oxy-Acetylene Welding – Within the preceding 15 calendar months, but at least once each calendar year, the welder shall re-qualify according to Section III, C and IV, B of this procedure; or within the preceding 7 ½ calendar months, but at least twice each calendar year, the welder has one 2" butt-weld tested and found acceptable in accordance with the initial qualifying test.

VIII. RECORDS FOR QUALIFYING PIPELINE WELDERS

* Welder qualification records shall be prepared, distributed for signatures, and maintained by Engineering. Form [1095A](#) shall be used to record the results of the welder metal-arc butt-weld test. Form [1095B](#) shall be used to record the results of the welder metal-arc fillet-weld test Form [1095C](#) shall be used to record the oxy-acetylene butt-weld test. The welder qualification records shall be kept permanently by Engineering.

* Revised Text