

METROPOLITAN UTILITIES DISTRICT	Construction Standard	No: 8.3.3
	Trace Wire, Anode and Test Lead Attachment Methods For Steel, Ductile Iron And Cast Iron Water Mains	Page: 1 of 6
Prepared by: Bill Travnicsek		<u>Supersedes:</u> 10-30-09
Approved by: Jeff Loll		Effective: 1-31-10

Scope: The following procedures cover the various approved methods of attaching anode leads, test leads, and trace wire to steel, ductile iron and cast iron water mains. Other methods may be considered for use with prior approval from the M.U.D. Engineering Department.

Note: Use thermite bonding for steel pipe, thermite bonding or cathode-clamp for ductile iron pipe, and cathode-clamp for cast iron pipe.

Thermite Bonding (Steel and Ductile Iron Pipe)

A thermite bonding kit is used to attach anode leads, test leads, and trace wire to steel and ductile iron pipe and fittings. The kit consists of copper sleeves, metal melting discs, flash powder, crucible (graphite block mold), a flint gun to ignite the powder, and a tool to clean slag from the crucible. The crucible is used to control ignition and the flow of molten metal on top of the test/anode lead to bond it to the steel.

1. Clean a 2 to 3 inch square on top of the steel or ductile iron pipe, as in Fig 1, and file down to bare shiny metal. Remove 1-1/2 inches of insulation from the anode connector wire end. Slide a copper sleeve on to the connector wire end and crimp it. Cut off the remaining wire or bend the end of the connector wire over the sleeve. See Fig 2. Tug on the sleeve to ensure it is tight.

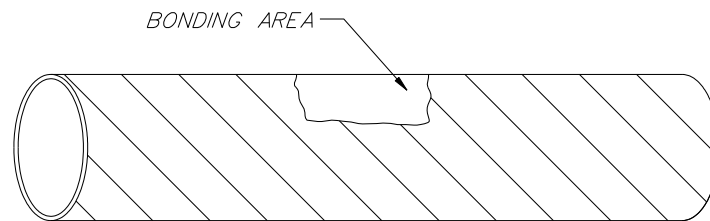

FIG 1

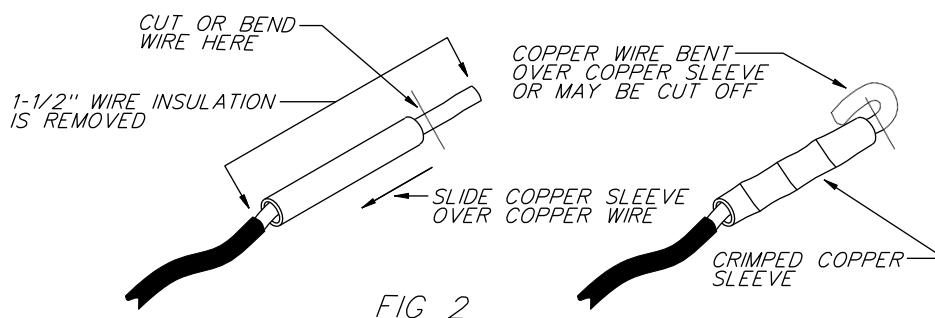

FIG 2

2. Place a metal disc, point down, in the bottom of the crucible and pour the flash powder (gray) on top of the disc. Ensure that the igniter powder (silver) in the very bottom of the plastic container is on top of the powder in the crucible or ignition may not take place. Keep the crucible in an upright position at all times to avoid spilling the powder. **Note:** The flash powder is the same for both steel and ductile iron pipe.
3. Center the copper sleeve and connector wire in the bonding area parallel to the pipe.

METROPOLITAN UTILITIES DISTRICT	Construction Standard	No: 8.3.3
	Trace Wire, Anode and Test Lead Attachment Methods For Steel, Ductile Iron And Cast Iron Water Mains	Page: 2 of 6
Prepared by: Bill Travnicsek		Supersedes: 10-30-09
Approved by: Jeff Loll		Effective: 1-31-10

4. Place the crucible over the connector wire and hold firmly in an upright position. See Fig 3. The clip on the side of the crucible may be used to hold the wire in place. Fig 4 shows the bottom view of the crucible centered over the connector wire end.

5. Gloves and goggles shall be worn and long sleeves recommended during ignition. **Warning:** Make sure that no part of the body or anything flammable is directly under the pipe because molten metal may escape from the crucible and cause serious injury, damage to other pipe and fittings, and/or fire. **Caution:** If molten metal is released from the crucible, pipe coatings and any plastic pipe and fittings in the immediate area should be inspected for damage and repaired as necessary.

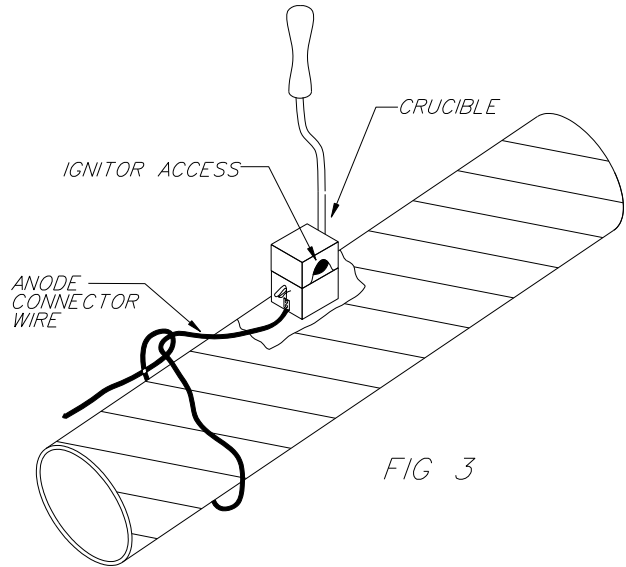

6. Close the crucible lid and ignite the powder with the flint gun through the lid opening shown in Fig 3. Hold the crucible in place for 5 seconds.

7. Remove the crucible and clean the slag from the inside and bottom of the crucible. Check the connection by tugging on the connector wire and tapping the weld with a hammer or other suitable tool as in Fig 5.

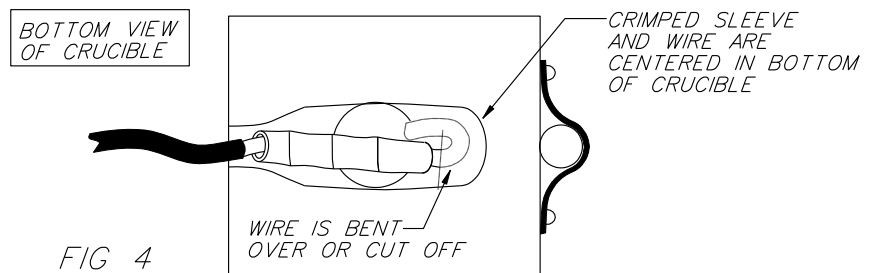

8. Apply primer and cold wrap according to Construction Standard [8.5.2](#). This applies to ductile iron and steel pipe.

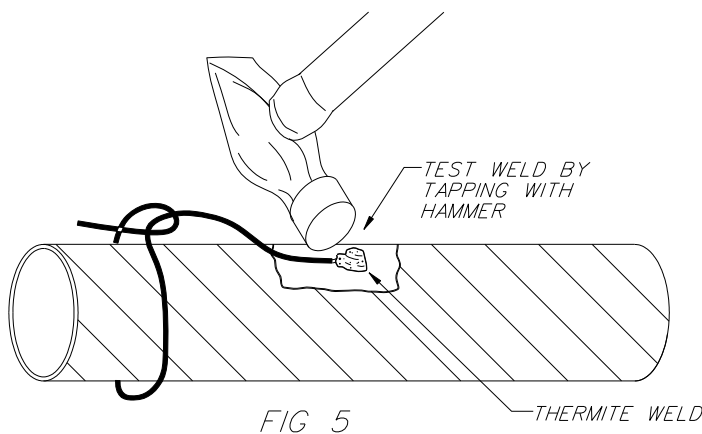

METROPOLITAN UTILITIES DISTRICT	Construction Standard	No: 8.3.3
	Trace Wire, Anode and Test Lead Attachment Methods For Steel, Ductile Iron And Cast Iron Water Mains	Page: 3 of 6
Prepared by: Bill Travnicsek		Supersedes: 10-30-09
Approved by: Jeff Loll		Effective: 1-31-10

Attaching Anodes To 3” – 18” Cast Iron or Ductile Iron Pipe

- * *Note: Cathodi-Clamp®, shown in Figures 9 through 12, is a registered trademark of CP Solutions, Inc.*

Materials:

- * Cathodi-Clamp®
32# anode
Wire connector

Tools:

- Wire brush
Socket or wrench
Continuity tester

Note: For cast iron or ductile iron mains larger than 18”, contact the Corrosion Engineer.

* Installation of Cathodi-Clamp®

1. Clean around the cast iron pipe surface with a wire brush to remove rust scale and dirt, so the band will lay flat against the pipe. For ductile iron pipe, remove the factory coating and file to smooth the surface where the pigtail connector bolt will contact the pipe surface.
2. Wrap the band around the pipe with wire pigtail and connector bolt at the 12 o’clock position. See Fig 6.

**

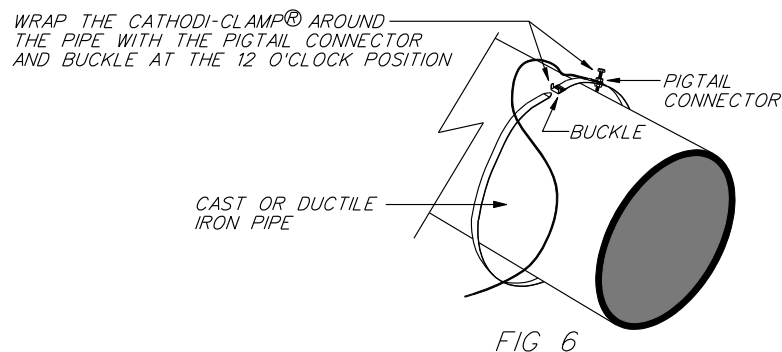

3. Insert the free end of band into buckle, as shown in Fig 7, making sure band is resting flat against pipe surface.

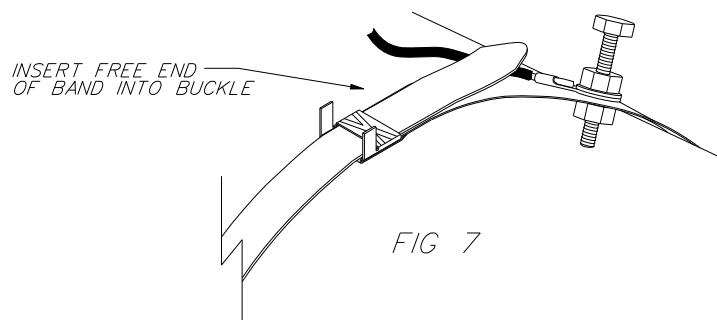

* Revised Text

** Revised Drawing

METROPOLITAN UTILITIES DISTRICT	Construction Standard	No: 8.3.3
	Trace Wire, Anode and Test Lead Attachment Methods For Steel, Ductile Iron And Cast Iron Water Mains	Page: 4 of 6
Prepared by: Bill Travnicsek		<u>Supersedes:</u> 10-30-09
Approved by: Jeff Loll		Effective: 1-31-10

4. Pull on free end to place band in slight tension around pipe.
5. Bend free end back against inside edge of buckle to hold band securely to pipe. See Fig 8.

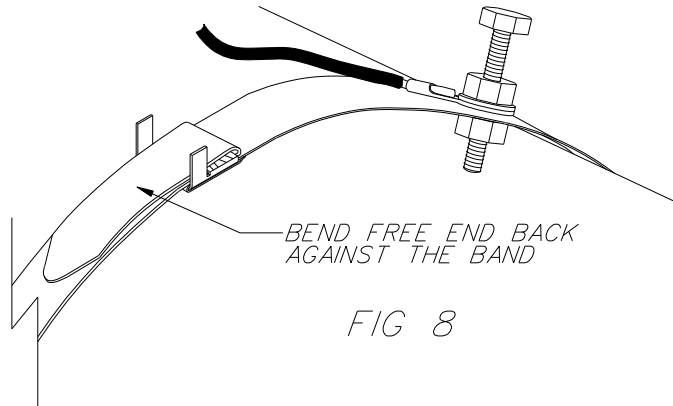

6. Lightly strike fastener "wings" of buckle with mallet or hammer holding free end in place as shown in Fig 9.

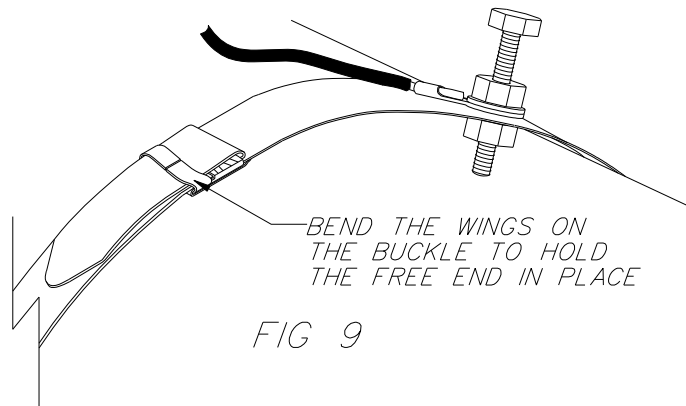

7. Excess length of free end of band may be cut with snips (Fig 10) or may remain in place.

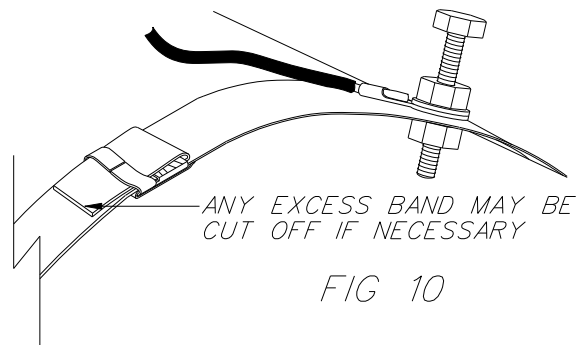

METROPOLITAN UTILITIES DISTRICT	Construction Standard	No: 8.3.3
	Trace Wire, Anode and Test Lead Attachment Methods For Steel, Ductile Iron And Cast Iron Water Mains	Page: 5 of 6
Prepared by: Bill Travnicek		Supersedes: 10-30-09
Approved by: Jeff Loll		Effective: 1-31-10

8. Loosen the adjusting nut on the top of the band. See Fig 11.

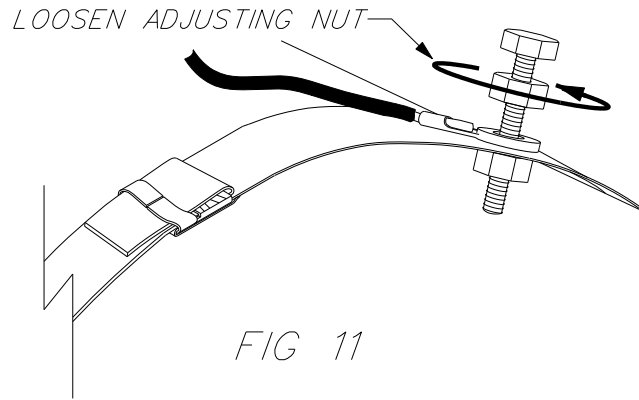

9. Using socket or wrench, hand tighten the hex cap bolt to draw the band tight around the pipe. See Fig 12.

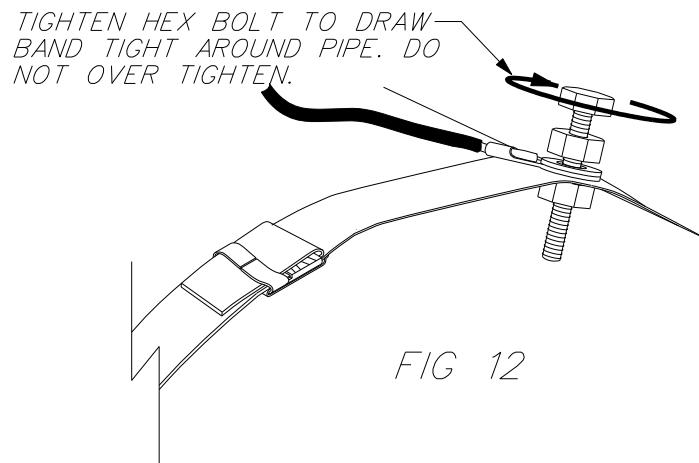

10. Hand-tighten the adjusting nut on the top of the band – do not over-tighten the bolt or nut. See Fig 13.

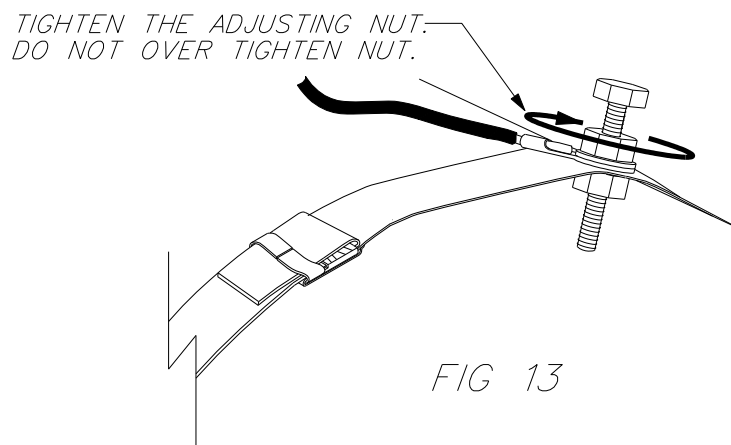

METROPOLITAN UTILITIES DISTRICT	Construction Standard	No: 8.3.3
Prepared by: Bill Travnicsek	Trace Wire, Anode and Test Lead Attachment Methods For Steel, Ductile Iron And Cast Iron Water Mains	Page: 6 of 6
Approved by: Jeff Loll		Supersedes: 10-30-09
		Effective: 1-31-10

11. Verify continuity with continuity tester, one end attached to copper end of wire pigtail, the other end contacting the cast iron pipe. *Note: If there is no continuity, make sure that pipe surface at contact is clean; tighten hex bolt cap 1/4 turn at a time until continuity is established.*
12. Place a 32# anode in the ditch; remove 1" of insulation from the end of anode wire, exposing the copper.
- * 13. Hold anode wire end and Cathodi-Clamp® pigtail end together with ends even.
14. Screw on connector, pushing wires firmly through the pie shaped cap. No copper wire should be left exposed outside of the connector cap. See Fig 14.

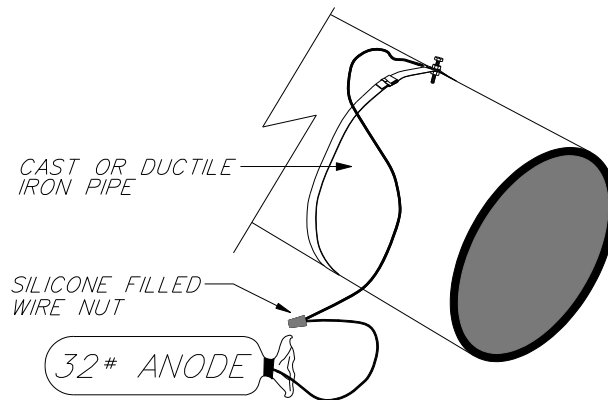

FIG 14

* Revised Text